

**AP**[®]

Physics 1 Practice Exam and Notes

Updated

Question 16 has been replaced.

The equation sheet has been revised:

In the MECHANICS section:

“ A = amplitude” was previously omitted from the list of definitions.

“ y = height” replaces the previous “ h = height” in the list of definitions.

Important Note

This Practice Exam is provided by the College Board for AP Exam preparation. Teachers are permitted to download the materials and make copies to use with their students in a classroom setting only. To maintain the security of this exam, teachers should collect all materials after their administration and keep them in a secure location.

Exams may not be posted on school or personal websites, nor electronically redistributed for any reason. Further distribution of these materials outside of the secure College Board site disadvantages teachers who rely on uncirculated questions for classroom testing. Any additional distribution is in violation of the College Board’s copyright policies and may result in the termination of Practice Exam access for your school as well as the removal of access to other online services such as the AP Teacher Community and Online Score Reports.

Effective Fall 2014

About the College Board®

The College Board is a mission-driven not-for-profit organization that connects students to college success and opportunity. Founded in 1900, the College Board was created to expand access to higher education. Today, the membership association is made up of over 6,000 of the world's leading educational institutions and is dedicated to promoting excellence and equity in education. Each year, the College Board helps more than seven million students prepare for a successful transition to college through programs and services in college readiness and college success — including the SAT® and the Advanced Placement Program®. The organization also serves the education community through research and advocacy on behalf of students, educators, and schools.

For further information visit www.collegeboard.org.

AP Equity and Access Policy

The College Board strongly encourages educators to make equitable access a guiding principle for their AP programs by giving all willing and academically prepared students the opportunity to participate in AP. We encourage the elimination of barriers that restrict access to AP for students from ethnic, racial and socioeconomic groups that have been traditionally underserved. Schools should make every effort to ensure their AP classes reflect the diversity of their student population. The College Board also believes that all students should have access to academically challenging course work before they enroll in AP classes, which can prepare them for AP success. It is only through a commitment to equitable preparation and access that true equity and excellence can be achieved.



Contents

INTRODUCTION	4
I. PRACTICE EXAM	
Exam Content and Format	7
Administering the Practice Exam	7
Student Answer Sheet for Multiple-Choice Section	9
AP [®] Physics 1 Practice Exam	10
II. NOTES ON THE PRACTICE EXAM	
Introduction	53
Multiple-Choice Section	55
Free-Response Section	91



Introduction

Beginning in 2014-15, AP Physics 1: Algebra-Based will focus on the big ideas typically included in the first semester of an algebra-based, introductory college-level physics sequence.* The course covers Newtonian mechanics (including rotational dynamics and angular momentum); work, energy, and power; mechanical waves and sound. It will also introduce electric circuits. The revised exam will include a reduced number of multiple-choice and free-response questions, and will include a new experimental-design question that demonstrates understanding of the science practices.

Part I of this publication is the AP Physics 1 Practice Exam. This will mirror the look and feel of an actual AP Exam, including instructions and sample questions. However, these exam items have never been administered in an operational exam, and, therefore, statistical analysis is **not** available. The purpose of this section is to provide educators with sample exam questions that accurately reflect the composition and design of the revised exam and to offer these questions in a way that gives teachers the opportunity to test their students in an exam situation that closely resembles the actual exam administration.

Part II is the Notes on the AP Physics 1 Practice Exam. This section offers detailed explanations of how each question in the practice exam links back to the AP Physics 1: Algebra-based and AP Physics 2: Algebra-based curriculum framework (Notes) in order to provide a clear link between curriculum and assessment. It also explains why the correct answer is the correct choice and why the other answers are incorrect (Rationales).

How AP Courses and Exams Are Developed

AP courses and exams are designed by committees of college faculty and AP teachers who ensure that each AP course and exam reflects and assesses college-level expectations. These committees define the scope and expectations of the course, articulating through a curriculum framework what students should know and be able to do upon completion of the AP course. Their work is informed by data collected from a range of colleges and universities to ensure that AP course work reflects current scholarship and advances in the discipline.

These same committees are also responsible for designing and approving exam specifications and exam questions that clearly connect to the curriculum framework. The AP Exam development process is a multi-year endeavor; all AP Exams undergo extensive review, revision, piloting, and analysis to ensure that questions are high quality and fair and that the questions comprise an appropriate range of difficulty.

Throughout AP course and exam development, the College Board gathers feedback from secondary and post-secondary educators. This feedback is carefully considered to ensure that AP courses and exams provide students with a college-level learning experience and the opportunity to demonstrate their qualifications for advanced placement and college credit upon college entrance.

* The AP Program has replaced AP Physics B with two new courses: AP Physics 1 and AP Physics 2. Resources for AP Physics 2 will be available separately.

Course Development

Each committee first articulates its discipline's high-level goals and then identifies the course's specific learning objectives. This approach is consistent with "backward design," the practice of developing curricula, instruction, and assessments with the end goal in mind. The learning objectives describe what students should know and be able to do, thereby providing clear instructional goals as well as targets of measurement for the exam.

Exam Development

Exam development begins with the committee making decisions about the overall nature of the exam. How long will it be? How many multiple-choice questions? How many free-response questions? How much time will be devoted to each section? How will the course content and skills be distributed across each section of the exam? Answers to these questions become part of the exam specifications.

With the exam specifications set, test developers design questions that conform to these specifications. The committee reviews every exam question for alignment with the curriculum framework, content accuracy, and a number of other criteria that ensure the integrity of the exam.

Exam questions are then piloted in AP classrooms to determine their statistical properties. Questions that have been approved by the committee and piloted successfully are included in an exam. When an exam is assembled, the committee conducts a final review of the exam to ensure overall conformity with the specifications.

How AP Exams Are Scored

The exam scoring process, like the course and exam development process, relies on the expertise of both AP teachers and college faculty. While multiple-choice questions are scored by machine, the free-response questions are scored by thousands of college faculty and expert AP teachers at the annual AP Reading. AP Exam Readers are thoroughly trained, and their work is monitored throughout the Reading for fairness and consistency. In each subject, a highly respected college faculty member fills the role of Chief Reader, who, with the help of AP Readers in leadership positions, maintains the accuracy of the scoring standards. Scores on the free-response questions are weighted and combined with the results of the computer-scored multiple-choice questions, and this raw score is summed to give a composite AP score of 5, 4, 3, 2, or 1.

The score-setting process is both precise and labor intensive, involving numerous psychometric analyses of the results of a specific AP Exam in a specific year and of the particular group of students who took that exam. Additionally, to ensure alignment with college-level standards, part of the score-setting process involves comparing the performance of AP students with the performance of students enrolled in comparable courses in colleges throughout the United States. In general, the AP composite score points are set so that the lowest raw score needed to earn an AP score of 5 is equivalent to the average score among college students earning grades of A in the college course. Similarly, AP Exam scores of 4 are equivalent to college grades of A–, B+, and B. AP Exam scores of 3 are equivalent to college grades of B–, C+, and C.

Using and Interpreting AP Scores

The extensive work done by college faculty and AP teachers in the development of the course and the exam and throughout the scoring process ensures that AP Exam scores accurately represent students' achievement in the equivalent college course. While colleges and universities are responsible for setting their own credit and placement policies, AP scores signify how qualified students are to receive college credit and placement:

AP Score	Qualification
5	Extremely well qualified
4	Well qualified
3	Qualified
2	Possibly qualified
1	No recommendation

Additional Resources

Visit apcentral.collegeboard.org for more information about the AP Program.



Practice Exam

Exam Content and Format

The AP Physics 1 Exam is approximately 3 hours in length. There are two sections:

- Section I is 90 minutes in length and consists of 50 multiple-choice questions accounting for 50 percent of the final score.
- Section II is 90 minutes in length and consists of 5 free-response questions accounting for 50 percent of the final score.

Administering the Practice Exam

This section contains instructions for administering the AP Physics 1 Practice Exam. You may wish to use these instructions to create an exam situation that resembles an actual administration. If so, read the indented, boldface directions to the students; all other instructions are for administering the exam and need not be read aloud. Before beginning testing, have all exam materials ready for distribution. These include test booklets, answer sheets, the AP Physics 1 Table of Information and Equations list, and calculators.

SECTION I: Multiple-Choice Questions

When you are ready to begin Section I, say:

Section I is the multiple-choice portion of the exam. Mark all of your responses on your answer sheet, one response per question. If you need to erase, do so carefully and completely. Your score on the multiple-choice section will be based solely on the number of questions answered correctly. You may use a scientific/graphing calculator and Physics 1 Table of Information and Equations list during this ENTIRE section. Are there any questions?

You have 90 minutes for this section. Open your Section I booklet and begin.

Note Start Time here _____. Note Stop Time here _____. Check that students are marking their answers in pencil on their answer sheets, and that they are not looking at their Section II booklets. After 90 minutes, say:

Stop working. I will now collect your Section I booklet.

There is a 10-minute break between Sections I and II. When all Section I materials have been collected and accounted for and you are ready for the break, say:

Please listen carefully to these instructions before we take a 10-minute break. Leave your Section II packet on your desk during the break. Are there any questions?

You may begin your break. Testing will resume at _____.

SECTION II: Free-Response Questions

After the break, say:

You have 90 minutes to answer the questions in this section. You are responsible for pacing yourself, and may proceed freely from one question to the next. Write your answers in the space provided for each part of a question. If you need more paper during the exam, raise your hand. At the top of each extra piece of paper you use, be sure to write your name and the number and part of the question you are working on. You may use a scientific/graphing calculator and Physics 1 Table of Information and Equations list during this ENTIRE section. Are there any questions?

You have 90 minutes for this section. Open your Section II booklet and begin.

Note Start Time here_____. Note Stop Time here_____. Check that students are writing their answers in their exam booklets. After 80 minutes, say:

There are 10 minutes remaining.

After 10 minutes, say:

Stop working and close your exam booklet. Put your exam booklet on your desk, face up. Remain in your seat, without talking, while the exam materials are collected.

If any students used extra paper for the free-response section, have those students staple the extra sheet/s to the first page corresponding to that question in their exam booklets. Collect a Section II booklet from each student and check that each student wrote answers on the lined pages corresponding to each question.

Then say:

You are now dismissed.

Name: _____

AP[®] Physics 1
Student Answer Sheet
for Multiple-Choice Section

No.	Answer
1	
2	
3	
4	
5	
6	
7	
8	
9	
10	
11	
12	
13	
14	
15	
16	
17	
18	
19	
20	
21	
22	
23	
24	
25	
26	
27	
28	
29	
30	

No.	Answer
31	
32	
33	
34	
35	
36	
37	
38	
39	
40	
41	
42	
43	
44	
45	

46		
47		
48		
49		
50		

AP[®] Physics 1 Practice Exam

SECTION I: Multiple Choice

DO NOT OPEN THIS BOOKLET UNTIL YOU ARE TOLD TO DO SO.

At a Glance

Total Time

90 minutes

Number of Questions

50

Percent of Total Score

50%

Writing Instrument

Pencil required

Electronic Device

Calculator allowed

Instructions

Section I of this exam contains 50 multiple-choice questions. Pages containing equations and other information are also printed in this booklet. Calculators, rulers, and straightedges may be used in this section.

Indicate all of your answers to the multiple-choice questions on the answer sheet. No credit will be given for anything written in this exam booklet, but you may use the booklet for notes or scratch work.

For questions 1 through 45, select the single best answer choice for each question. After you have decided which of the choices is best, fill in the appropriate letter in the corresponding space on the answer sheet.

For questions 46 through 50, select the two best answer choices for each question. After you have decided which two of the choices are best, enter both letters in the corresponding space on the answer sheet.

Use your time effectively, working as quickly as you can without losing accuracy. Do not spend too much time on any one question. Go on to other questions and come back to the ones you have not answered if you have time. It is not expected that everyone will know the answers to all of the multiple-choice questions.

Your total score on Section I is based only on the number of questions answered correctly. Points are not deducted for incorrect answers or unanswered questions.

NO TEST MATERIAL ON THIS PAGE

AP[®] PHYSICS 1 TABLE OF INFORMATION

CONSTANTS AND CONVERSION FACTORS

Proton mass, $m_p = 1.67 \times 10^{-27}$ kg Neutron mass, $m_n = 1.67 \times 10^{-27}$ kg Electron mass, $m_e = 9.11 \times 10^{-31}$ kg Speed of light, $c = 3.00 \times 10^8$ m/s	Electron charge magnitude, $e = 1.60 \times 10^{-19}$ C Coulomb's law constant, $k = 1/4\pi\epsilon_0 = 9.0 \times 10^9$ N·m ² /C ² Universal gravitational constant, $G = 6.67 \times 10^{-11}$ m ³ /kg·s ² Acceleration due to gravity at Earth's surface, $g = 9.8$ m/s ²
---	--

UNIT SYMBOLS	meter, m	kelvin, K	watt, W	degree Celsius, °C
	kilogram, kg	hertz, Hz	coulomb, C	
	second, s	newton, N	volt, V	
	ampere, A	joule, J	ohm, Ω	

PREFIXES		
Factor	Prefix	Symbol
10^{12}	tera	T
10^9	giga	G
10^6	mega	M
10^3	kilo	k
10^{-2}	centi	c
10^{-3}	milli	m
10^{-6}	micro	μ
10^{-9}	nano	n
10^{-12}	pico	p

VALUES OF TRIGONOMETRIC FUNCTIONS FOR COMMON ANGLES							
θ	0°	30°	37°	45°	53°	60°	90°
$\sin \theta$	0	1/2	3/5	$\sqrt{2}/2$	4/5	$\sqrt{3}/2$	1
$\cos \theta$	1	$\sqrt{3}/2$	4/5	$\sqrt{2}/2$	3/5	1/2	0
$\tan \theta$	0	$\sqrt{3}/3$	3/4	1	4/3	$\sqrt{3}$	∞

The following conventions are used in this exam.

- I. The frame of reference of any problem is assumed to be inertial unless otherwise stated.
- II. Assume air resistance is negligible unless otherwise stated.
- III. In all situations, positive work is defined as work done on a system.
- IV. The direction of current is conventional current: the direction in which positive charge would drift.
- V. Assume all batteries and meters are ideal unless otherwise stated.

AP® PHYSICS 1 EQUATIONS

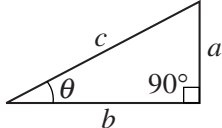
MECHANICS	ELECTRICITY		
$v_x = v_{x0} + a_x t$ $x = x_0 + v_{x0} t + \frac{1}{2} a_x t^2$ $v_x^2 = v_{x0}^2 + 2a_x(x - x_0)$ $\vec{a} = \frac{\sum \vec{F}}{m} = \frac{\vec{F}_{net}}{m}$ $ \vec{F}_f \leq \mu \vec{F}_n $ $a_c = \frac{v^2}{r}$ $\vec{p} = m\vec{v}$ $\Delta\vec{p} = \vec{F} \Delta t$ $K = \frac{1}{2} m v^2$ $\Delta E = W = F_{\parallel} d = F d \cos \theta$ $P = \frac{\Delta E}{\Delta t}$ $\theta = \theta_0 + \omega_0 t + \frac{1}{2} \alpha t^2$ $\omega = \omega_0 + \alpha t$ $x = A \cos(2\pi f t)$ $\vec{\alpha} = \frac{\sum \vec{\tau}}{I} = \frac{\vec{\tau}_{net}}{I}$ $\tau = r_{\perp} F = r F \sin \theta$ $L = I \omega$ $\Delta L = \tau \Delta t$ $K = \frac{1}{2} I \omega^2$ $ \vec{F}_s = k \vec{x} $ $U_s = \frac{1}{2} k x^2$ $\rho = \frac{m}{V}$	$a = \text{acceleration}$ $A = \text{amplitude}$ $d = \text{distance}$ $E = \text{energy}$ $f = \text{frequency}$ $F = \text{force}$ $I = \text{rotational inertia}$ $K = \text{kinetic energy}$ $k = \text{spring constant}$ $L = \text{angular momentum}$ $\ell = \text{length}$ $m = \text{mass}$ $P = \text{power}$ $p = \text{momentum}$ $r = \text{radius or separation}$ $T = \text{period}$ $t = \text{time}$ $U = \text{potential energy}$ $V = \text{volume}$ $v = \text{speed}$ $W = \text{work done on a system}$ $x = \text{position}$ $y = \text{height}$ $\alpha = \text{angular acceleration}$ $\mu = \text{coefficient of friction}$ $\theta = \text{angle}$ $\rho = \text{density}$ $\tau = \text{torque}$ $\omega = \text{angular speed}$ $\Delta U_g = m g \Delta y$ $T = \frac{2\pi}{\omega} = \frac{1}{f}$ $T_s = 2\pi \sqrt{\frac{m}{k}}$ $T_p = 2\pi \sqrt{\frac{\ell}{g}}$ $ \vec{F}_g = G \frac{m_1 m_2}{r^2}$ $\vec{g} = \frac{\vec{F}_g}{m}$ $U_G = -\frac{G m_1 m_2}{r}$		
	$ \vec{F}_E = k \left \frac{q_1 q_2}{r^2} \right $ $I = \frac{\Delta q}{\Delta t}$ $R = \frac{\rho \ell}{A}$ $I = \frac{\Delta V}{R}$ $P = I \Delta V$ $R_s = \sum_i R_i$ $\frac{1}{R_p} = \sum_i \frac{1}{R_i}$ <p align="center">WAVES</p> $\lambda = \frac{v}{f}$ $f = \text{frequency}$ $v = \text{speed}$ $\lambda = \text{wavelength}$		
	<p align="center">GEOMETRY AND TRIGONOMETRY</p> <table style="width: 100%; border: none;"> <tr> <td style="width: 50%; vertical-align: top; padding: 5px;"> Rectangle $A = bh$ Triangle $A = \frac{1}{2} bh$ Circle $A = \pi r^2$ $C = 2\pi r$ Rectangular solid $V = \ell wh$ Cylinder $V = \pi r^2 \ell$ $S = 2\pi r \ell + 2\pi r^2$ Sphere $V = \frac{4}{3} \pi r^3$ $S = 4\pi r^2$ </td> <td style="width: 50%; vertical-align: top; padding: 5px;"> $A = \text{area}$ $C = \text{circumference}$ $V = \text{volume}$ $S = \text{surface area}$ $b = \text{base}$ $h = \text{height}$ $\ell = \text{length}$ $w = \text{width}$ $r = \text{radius}$ Right triangle $c^2 = a^2 + b^2$ $\sin \theta = \frac{a}{c}$ $\cos \theta = \frac{b}{c}$ $\tan \theta = \frac{a}{b}$ </td> </tr> </table> <div style="text-align: right; margin-top: 10px;">  </div>	Rectangle $A = bh$ Triangle $A = \frac{1}{2} bh$ Circle $A = \pi r^2$ $C = 2\pi r$ Rectangular solid $V = \ell wh$ Cylinder $V = \pi r^2 \ell$ $S = 2\pi r \ell + 2\pi r^2$ Sphere $V = \frac{4}{3} \pi r^3$ $S = 4\pi r^2$	$A = \text{area}$ $C = \text{circumference}$ $V = \text{volume}$ $S = \text{surface area}$ $b = \text{base}$ $h = \text{height}$ $\ell = \text{length}$ $w = \text{width}$ $r = \text{radius}$ Right triangle $c^2 = a^2 + b^2$ $\sin \theta = \frac{a}{c}$ $\cos \theta = \frac{b}{c}$ $\tan \theta = \frac{a}{b}$
Rectangle $A = bh$ Triangle $A = \frac{1}{2} bh$ Circle $A = \pi r^2$ $C = 2\pi r$ Rectangular solid $V = \ell wh$ Cylinder $V = \pi r^2 \ell$ $S = 2\pi r \ell + 2\pi r^2$ Sphere $V = \frac{4}{3} \pi r^3$ $S = 4\pi r^2$	$A = \text{area}$ $C = \text{circumference}$ $V = \text{volume}$ $S = \text{surface area}$ $b = \text{base}$ $h = \text{height}$ $\ell = \text{length}$ $w = \text{width}$ $r = \text{radius}$ Right triangle $c^2 = a^2 + b^2$ $\sin \theta = \frac{a}{c}$ $\cos \theta = \frac{b}{c}$ $\tan \theta = \frac{a}{b}$		

PHYSICS 1
Section I
50 Questions
Time—90 minutes

Note: To simplify calculations, you may use $g = 10 \text{ m/s}^2$ in all problems.

Directions: Each of the questions or incomplete statements below is followed by four suggested answers or completions. Select the one that is best in each case and then enter the appropriate letter in the corresponding space on the answer sheet.

1. An object is moving to the right with speed v_i when a force of magnitude F is exerted on it. In which of the following situations is the object's direction of motion changing and kinetic energy decreasing at the instant shown?

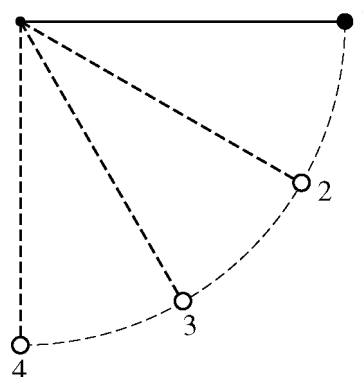
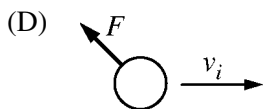
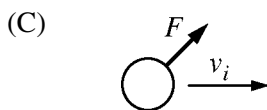
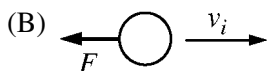
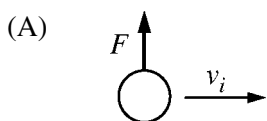

2. A ball is suspended by a lightweight string, as shown in the figure above. The ball is displaced to position 1 and released. The four labeled positions are evenly spaced along the arc of the ball's motion. Between which adjacent pairs of positions is the change in kinetic energy of the ball greatest?
- (A) 1 and 2
 (B) 2 and 3
 (C) 3 and 4
 (D) The change is the same for all adjacent pairs.



GO ON TO THE NEXT PAGE.

3. A newly discovered planet is found to have density $\frac{2}{3}\rho_E$ and radius $2R_E$, where ρ_E and R_E are the density and radius of Earth, respectively. The surface gravitational field of the planet is most nearly

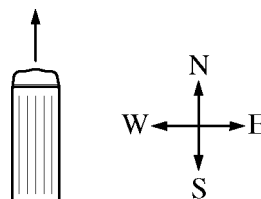
- (A) 1.7 N/kg
- (B) 3.3 N/kg
- (C) 6.7 N/kg
- (D) 13 N/kg

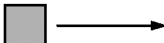
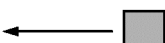

4. A bus is initially traveling north at a constant speed, as shown in the figure above. As the bus starts to make a left turn without changing speed, a passenger notices that a box on the floor starts sliding toward the right side of the bus. Which of the following top views of the box, when correctly labeled, would best represent all of the horizontal forces exerted on the box as it starts sliding?

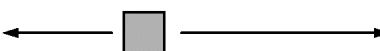
- (A) 
- (B) 
- (C) 
- (D) 

GO ON TO THE NEXT PAGE.

Questions 5-6 refer to the following material.

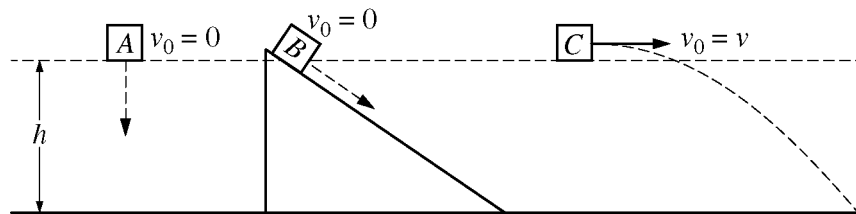

Three identical blocks each take a different path from a height h to the ground. Block A is released from rest and falls vertically. Block B is released from rest and slides down a frictionless incline. Block C is projected horizontally with an initial speed v .

5. Which block takes the longest time to reach the ground?

- (A) A
- (B) B
- (C) C
- (D) The blocks take the same time to reach the ground.

6. Which block has the greatest speed just before hitting the ground?

- (A) A
- (B) B
- (C) C
- (D) The blocks reach the ground with the same speed.

GO ON TO THE NEXT PAGE.

7. A ball is dropped from rest and falls to the floor. The initial gravitational potential energy of the ball-Earth-floor system is 10 J. The ball then bounces back up to a height where the gravitational potential energy is 7 J. What was the mechanical energy of the ball-Earth-floor system the instant the ball left the floor?

- (A) 0 J
 (B) 3 J
 (C) 7 J
 (D) 10 J

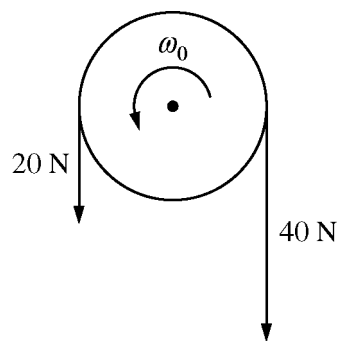

8. A disk is initially rotating counterclockwise around a fixed axis with angular speed ω_0 . At time $t = 0$, the two forces shown in the figure above are exerted on the disk. If counterclockwise is positive, which of the following could show the angular velocity of the disk as a function of time?

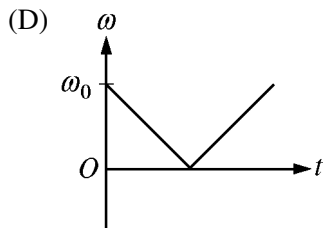
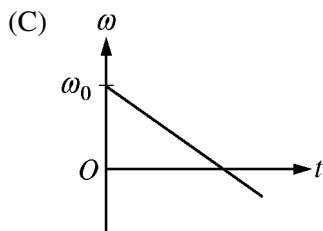
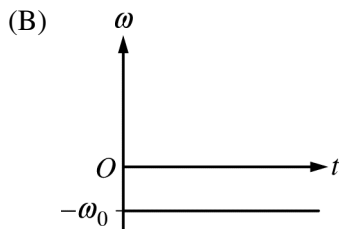
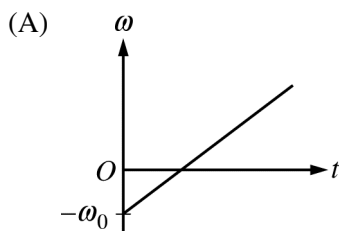

GO ON TO THE NEXT PAGE.

9. A 50.0 N box is at rest on a horizontal surface. The coefficient of static friction between the box and the surface is 0.50, and the coefficient of kinetic friction is 0.30. A horizontal 20.0 N force is then exerted on the box. The magnitude of the acceleration of the box is most nearly

- (A) 0 m/s²
 (B) 0.5 m/s²
 (C) 1.0 m/s²
 (D) 4.0 m/s²

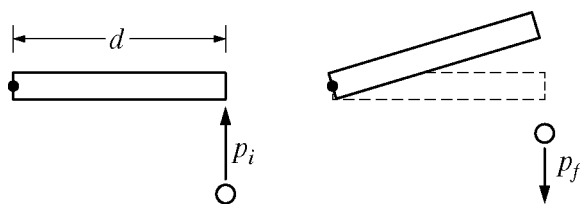

Top View

10. A thin rod of length d on a frictionless surface is pivoted about one end, as shown above, and can rotate freely. The rod is at rest when it is struck by a sphere with linear momentum of magnitude p_i perpendicular to the rod. The sphere rebounds along its original line of motion with momentum of magnitude p_f . What is the magnitude of the angular momentum of the rod immediately after the collision?

- (A) $p_f - p_i$
 (B) $p_f + p_i$
 (C) $(p_f - p_i)d$
 (D) $(p_f + p_i)d$

GO ON TO THE NEXT PAGE.

11. A spacecraft is placed in a circular orbit around a planet with mass 6.4×10^{23} kg. The spacecraft orbits at a height of 4.5×10^7 m above the planet's surface. What additional information is needed to calculate the speed of the spacecraft in the orbit?

- (A) No additional information
- (B) The planet's radius only
- (C) The spacecraft's mass only
- (D) Both the planet's radius and the spacecraft's mass



12. Two carts, of mass $2m$ and m , approach each other head-on with the same speed v , as shown in the figure above. When the carts collide, they hook together. Assuming positive momentum is to the right, which of the following best represents the momentum of the cart of mass m as a function of time before and after the collision?

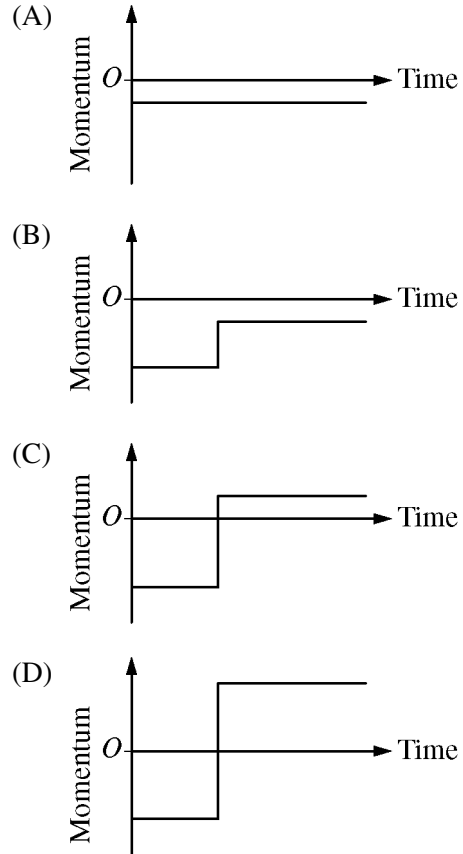

GO ON TO THE NEXT PAGE.

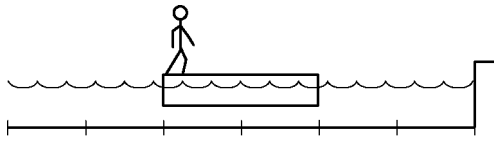

13. A student stands at one end of a raft floating in a pool with equally spaced marks along the bottom, as shown above. The student and the raft have the same mass. The student walks to the opposite end of the raft. Which of the following best shows the final locations of the raft and student relative to the marks at the bottom of the pool? Assume that there is no drag force between the raft and the water.

(A)

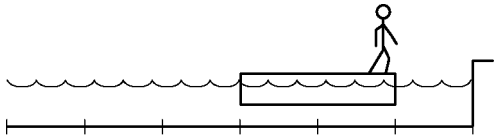

(B)

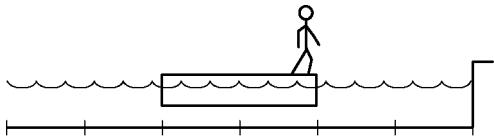

(C)

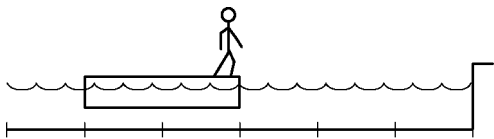

(D)

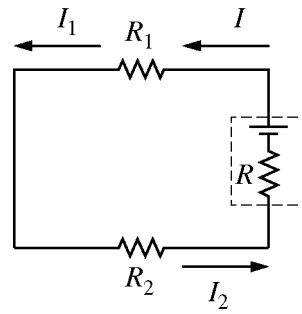
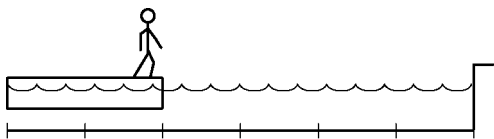

14. A circuit is designed with two resistors, $R_1 = 200 \, \Omega$ and $R_2 = 400 \, \Omega$, and a battery with internal resistance $R = 10 \, \Omega$, as shown above. What is the relationship between the three labeled currents?

(A) $I_1 + I_2 = I$

(B) $I > I_1 > I_2$

(C) $I_2 > I_1 > I$

(D) $I_1 = I_2 = I$

GO ON TO THE NEXT PAGE.

15. When two charged, massive objects are placed a distance r apart, the gravitational force between them has magnitude F . When the distance between the objects is increased to $2r$, the magnitude of the gravitational force between them becomes $F/4$. Did the electrostatic force between the objects also decrease to one fourth its initial magnitude as a result of the change in position, and why?

- (A) No, because the gravitational constant is much smaller than the electrostatic constant.
- (B) No, because the gravitational force is only attractive, and the electrostatic force can also be repulsive.
- (C) Yes, because both forces have the same $1/r^2$ dependence.
- (D) Yes, because the gravitational force always equals the electrostatic force at any given distance.

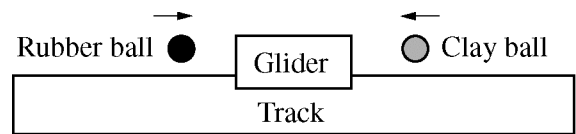

16. A clay ball and a rubber ball of the same mass are moving toward a glider that is at rest on a frictionless air track. The balls have the same speed, with the rubber ball moving toward the right and the clay ball moving toward the left, as shown above. The balls strike the glider at the same time. The clay ball sticks to the glider, and the rubber ball bounces off it. Which of the following indicates the direction of motion of the glider after the collisions and explains why it moves in that direction?
- (A) The glider moves to the right because the magnitude of the change in momentum of the rubber ball is greater than the magnitude of the change in momentum of the clay ball.
 - (B) The glider moves to the right because the collision with the rubber ball is elastic and conserves energy.
 - (C) The glider moves to the left because the clay ball has more inertia when it sticks to the glider than the rubber ball does when it bounces off.
 - (D) The glider moves to the left because the clay ball exerts a force on the glider for a longer time than the rubber ball does.

GO ON TO THE NEXT PAGE.

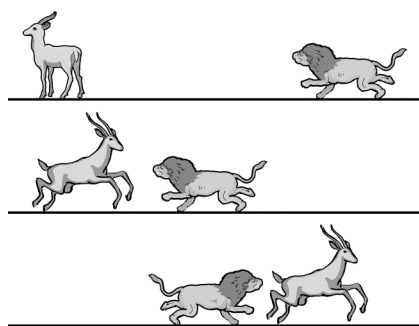

17. A lion is running at constant speed toward a gazelle that is standing still, as shown in the top figure above. After several seconds, the gazelle notices the lion and accelerates directly toward him, hoping to pass the lion and force him to reverse direction. As the gazelle accelerates toward and past the lion, the lion changes direction and accelerates in pursuit of the gazelle. The lion and the gazelle eventually each reach constant but different speeds. Which of the following sets of graphs shows a reasonable representation of the velocities of the lion and the gazelle as functions of time?

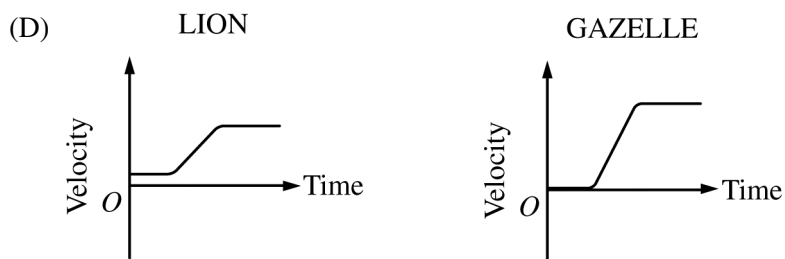
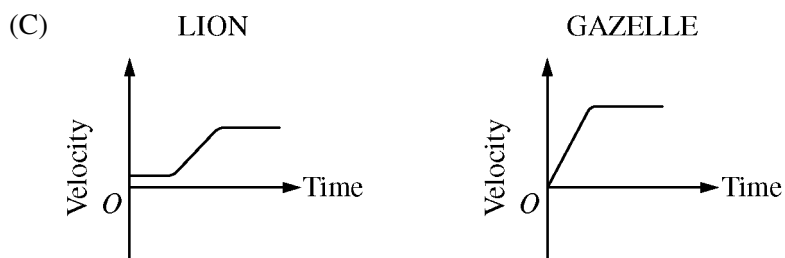
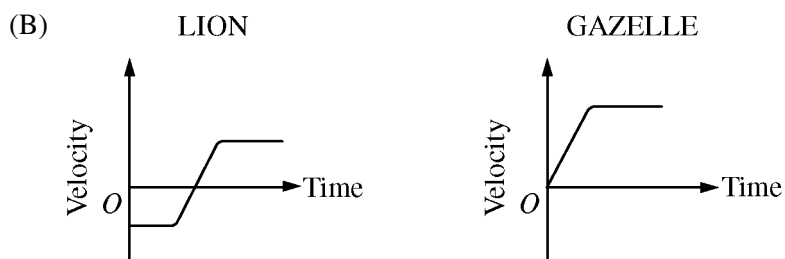
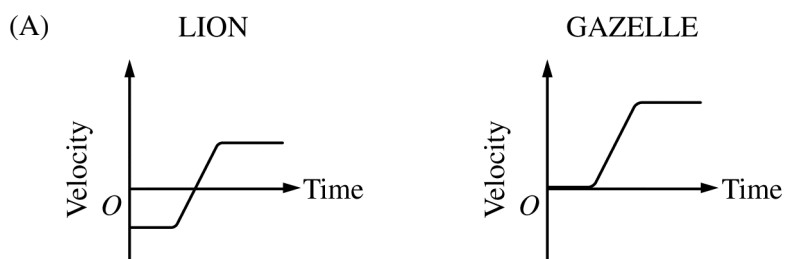

GO ON TO THE NEXT PAGE.

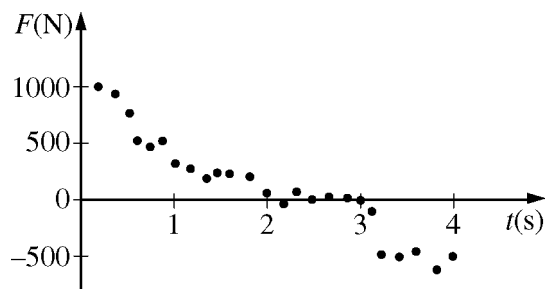

18. A spacecraft of mass 4000 kg is traveling in a straight line in the positive direction. Engines can be fired so that the force exerted on the spacecraft is in the positive or negative direction. The graph above shows data for the force during one interval. Which of the following is the best estimate of the net change in the speed of the spacecraft from time $t = 0$ to time $t = 4$ s?

- (A) +0.4 m/s
- (B) +0.1 m/s
- (C) -0.1 m/s
- (D) -0.4 m/s

19. A rocket is continuously firing its engines as it accelerates away from Earth. For the first kilometer of its ascent, the mass of fuel ejected is small compared to the mass of the rocket. For this distance, which of the following indicates the changes, if any, in the kinetic energy of the rocket, the gravitational potential energy of the Earth-rocket system, and the mechanical energy of the Earth-rocket system?

Rocket Kinetic Energy	System Gravitational Potential Energy	System Mechanical Energy
(A) Increasing	Increasing	Increasing
(B) Increasing	Increasing	Constant
(C) Increasing	Decreasing	Decreasing
(D) Decreasing	Increasing	Constant

GO ON TO THE NEXT PAGE.

20. Block 1 is attached to a spring and oscillates on a horizontal frictionless surface. When block 1 is at a point of maximum displacement, block 2 is placed on top of it from directly above without interrupting the oscillation, and the two blocks stick together. How do the maximum kinetic energy and period of oscillation with both blocks compare to those of block 1 alone?

	<u>Maximum Kinetic Energy</u>	<u>Period</u>
(A)	Smaller	Smaller
(B)	Smaller	Greater
(C)	The same	Smaller
(D)	The same	Greater

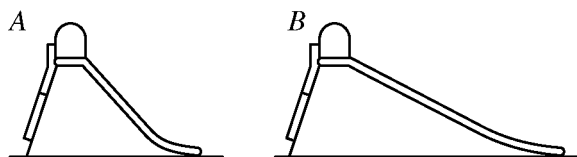

21. A child slides from rest down slides *A* and *B* shown above. The slides are the same height, and the coefficient of friction between the slides and the child is the same. Which of the following compares the change ΔK in the kinetic energy of the child and the change ΔU in the potential energy of the child-Earth system for the two slides?

- (A) $\Delta K_A = \Delta K_B$; $\Delta U_A = \Delta U_B$
 (B) $\Delta K_A < \Delta K_B$; $\Delta U_A > \Delta U_B$
 (C) $\Delta K_A > \Delta K_B$; $\Delta U_A = \Delta U_B$
 (D) $\Delta K_A > \Delta K_B$; $\Delta U_A > \Delta U_B$

GO ON TO THE NEXT PAGE.

Questions 22-24 refer to the following material.

A student is observing an object of unknown mass that is oscillating horizontally at the end of an ideal spring. The student measures the object's period of oscillation with a stopwatch.

22. The student wishes to determine the spring constant of the spring using the measurements of the period of oscillation. Which of the following pieces of equipment would provide another measured quantity that is sufficient information to complete the determination of the spring constant?

- (A) Meterstick
- (B) Motion sensor
- (C) Balance
- (D) Photogate

23. Using a number of measurements, the student determines the following.

Spring constant	85 N/m
Mass of object	0.50 kg
Amplitude of oscillation	0.30 m
Maximum speed of object	3.9 m/s

The total energy of the object-spring system is most nearly

- (A) 0.98 J
- (B) 3.8 J
- (C) 7.6 J
- (D) 12.8 J

24. While the object is continuously oscillating, the student determines the maximum speed of the object during two oscillations. The first speed is 3.5 m/s and the second speed is 2.7 m/s. Which of the following could account for the decrease in the object's maximum kinetic energy?

- (A) Energy was transferred from the object to the spring, which increased the maximum potential energy of the spring.
- (B) Energy was transferred from the spring to the object, which decreased the maximum potential energy of the spring.
- (C) As energy was transferred back and forth between the object and the spring, a greater average share of the energy became potential energy of the spring.
- (D) The object-spring system lost energy to its surroundings.

GO ON TO THE NEXT PAGE.

Questions 25-26 refer to the following material.

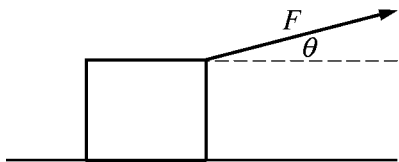

A crate is on a horizontal frictionless surface. A force of magnitude F is exerted on the crate at an angle θ to the horizontal, as shown in the figure above, causing the crate to slide to the right. The surface exerts a normal force of magnitude F_N on the crate. As the crate slides a distance d , it gains an amount of kinetic energy ΔK . While F is kept constant, the angle θ is now doubled but is still less than 90° . Assume the crate remains in contact with the surface.

25. How does the new normal force exerted on the crate compare to F_N ?
- (A) The new normal force is greater than F_N .
 - (B) The new normal force is less than F_N .
 - (C) The new normal force is equal to F_N .
 - (D) The new normal force is greater or less than F_N depending on the value of θ .
26. As the crate slides a distance d , how does the new gain in kinetic energy compare to ΔK ?
- (A) The new gain is greater than ΔK .
 - (B) The new gain is less than ΔK .
 - (C) The new gain is equal to ΔK .
 - (D) The new gain is greater or less than ΔK depending on the value of θ .

GO ON TO THE NEXT PAGE.

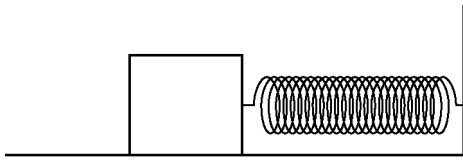

27. A block on a level surface is attached to one end of a spring, as shown in the figure above. The other end of the spring is attached to a wall. There is friction between the block and the surface. A person displaces the block from its equilibrium position and releases it. Which of the following shows the mechanical energy E as a function of time t for the system that includes only the block and the system that includes the block and spring?

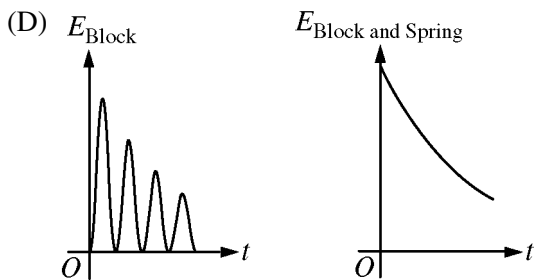
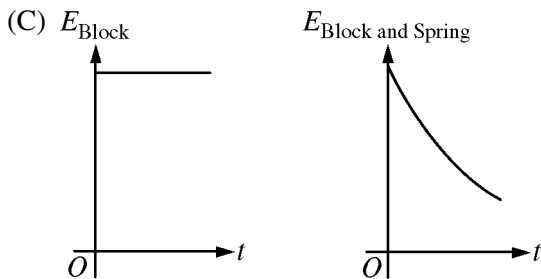
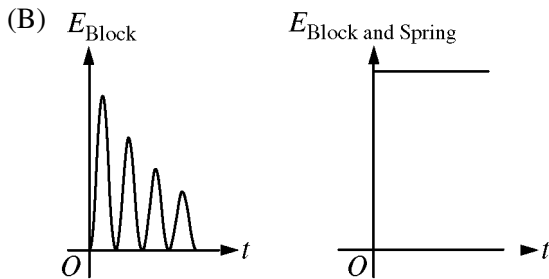
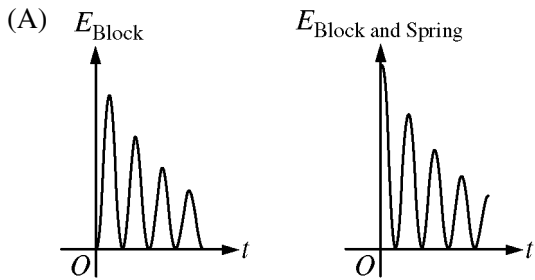

GO ON TO THE NEXT PAGE.

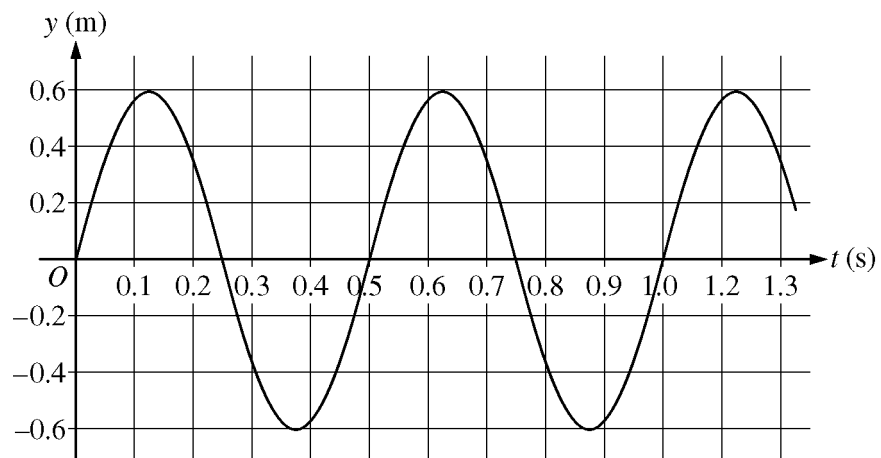

28. A transverse wave is traveling on a string. The graph above shows position as a function of time for a point on the string. If the frequency of the wave is doubled, what is the new average speed of the point?

- (A) 0 m/s
- (B) 2.4 m/s
- (C) 4.8 m/s
- (D) 9.6 m/s

GO ON TO THE NEXT PAGE.

29. Alan and Beverly are on opposite sides of a large room when Alan says something to Beverly. Beverly does not hear him, so Alan repeats the message louder and Beverly now hears it. Which of the following could be different about the second sound wave compared to the first that allows Beverly to hear it?

- (A) The second wave travels to Beverly more quickly, so less energy is dissipated by the time the wave reaches her.
- (B) The second wave reflects more off the walls of the room.
- (C) The air molecules disturbed by the second wave undergo a greater displacement from their equilibrium positions.
- (D) The air molecules disturbed by the second wave are, on average, more closely spaced.

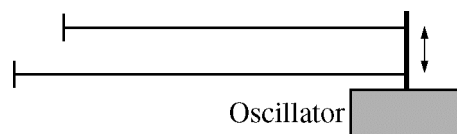

30. Two strings differing only in length are attached to the same oscillator, as shown in the figure above. Both are fixed at the other end and are under the same tension. The oscillator creates a transverse wave and is adjusted to the lowest frequency that creates a standing wave on the shorter string. Which of the following explains why there will not be a standing wave on the longer string?

- (A) The waves travel at slightly different speeds on the two strings.
- (B) An oscillator frequency that results in a standing wave on a string of one length cannot result in a standing wave on a string with a different length.
- (C) The amplitude of the wave does not match the boundary conditions for strings of different length at the same time.
- (D) The wavelength associated with the given frequency does not match the boundary conditions set by the length of the longer string.

GO ON TO THE NEXT PAGE.

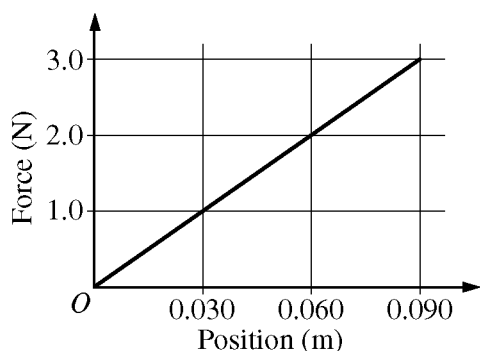

31. The figure above shows the net force exerted on an object as a function of the position of the object. The object starts from rest at position $x = 0$ m and acquires a speed of 3.0 m/s after traveling a distance of 0.090 m. What is the mass of the object?

- (A) 0.015 kg
- (B) 0.030 kg
- (C) 0.045 kg
- (D) 0.060 kg

32. Two identical carts are free to move along a straight frictionless track. At time t_1 , cart X is moving at 2.0 m/s when it collides with and sticks to cart Y , which is initially at rest. Which of the following graphs best shows the velocity of cart X before and after the collision?

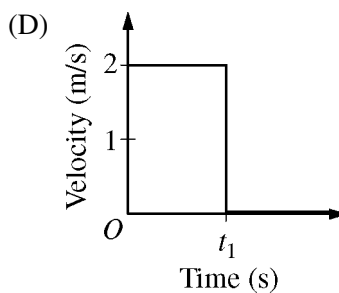
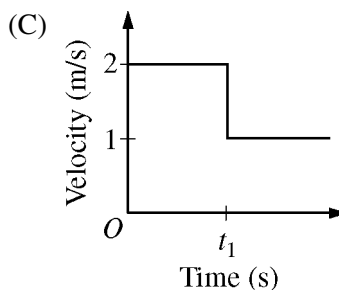
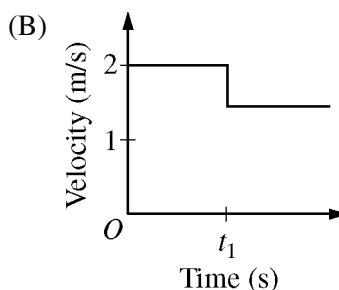
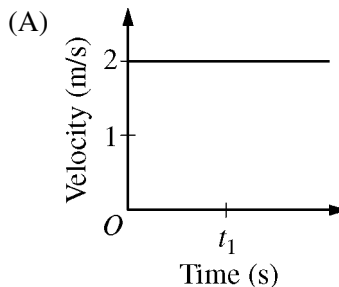

GO ON TO THE NEXT PAGE.

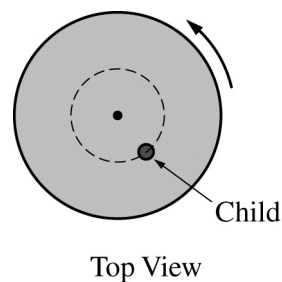
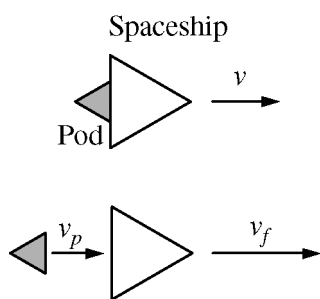

33. A spaceship and its shuttle pod are traveling to the right in a straight line with speed v , as shown in the top figure above. The mass of the pod is m , and the mass of the spaceship is $6m$. The pod is launched, and afterward the pod is moving to the right with speed v_p and the spaceship is moving to the right with speed v_f , where $v_f > v$, as shown in the bottom figure. Which of the following is true of the speed v_c of the center of mass of the system after the pod is launched?

- (A) $v_c = v_f$
- (B) $v < v_c < v_f$
- (C) $v_c < v$
- (D) $v_c = v$

34. The diagram above shows a top view of a child of mass M on a circular platform of mass $5M$ that is rotating counterclockwise. Assume the platform rotates without friction. Which of the following describes an action by the child that will result in an increase in the total angular momentum of the child-platform system?

- (A) The child moves toward the center of the platform.
- (B) The child moves away from the center of the platform.
- (C) The child moves along a circle concentric with the platform (dashed line shown) opposite the direction of the platform's rotation.
- (D) None of the actions described will change the total angular momentum of the child-platform system.

GO ON TO THE NEXT PAGE.

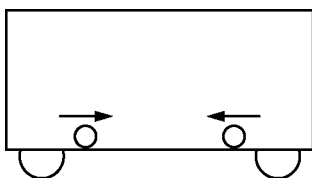

35. A train is traveling east with constant speed v_t . Two identical spheres are rolling on the floor of one train car. In the frame of reference of the train, the spheres are moving directly toward each other at one instant with the same speed v_p parallel to the train's motion, as shown in the figure above. What is the velocity of the center of mass of the spheres in the frame of reference of the train and in the frame of reference of a person standing at rest alongside the train?

<u>Train</u>	<u>Person</u>
(A) Zero	Zero
(B) Zero	v_t east
(C) v_t east	$v_p + v_t$ east
(D) $v_p + v_t$ east	Zero

36. A satellite that is a spinning cylinder has initial rotational inertia I_0 and angular velocity ω_0 . Solar panels unfold from the satellite and are extended outward. The satellite then has rotational inertia $I_f = aI_0$ and angular velocity $\omega_f = b\omega_0$, where a and b are constants. Which of the following is true about the constants a and b ?
- (A) $a = 1$ and $b = 1$
 (B) $a > 1$ and $b < 1$
 (C) $a > 1$ and $b = 1$
 (D) $a < 1$ and $b < 1$

GO ON TO THE NEXT PAGE.

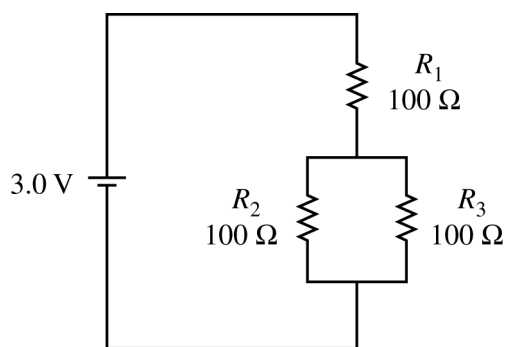

37. When the circuit shown above is set up, the potential difference across the battery is 3.0 V. By how much will the magnitude of the potential difference across R_2 change when R_3 is removed and its branch is left open?

- (A) The magnitude of the potential difference across R_2 does not change.
- (B) The magnitude of the potential difference across R_2 decreases by 0.5 V.
- (C) The magnitude of the potential difference across R_2 increases by 0.5 V.
- (D) The magnitude of the potential difference across R_2 increases by 1.0 V.

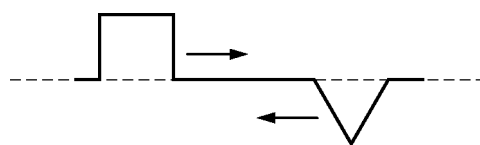

38. Two wave pulses are propagating along a straight line toward each other as shown above. Which of the following is the resultant when the centers of the pulses align?

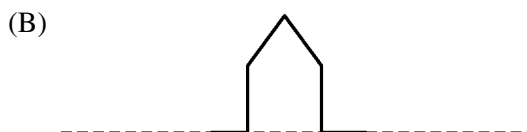

GO ON TO THE NEXT PAGE.

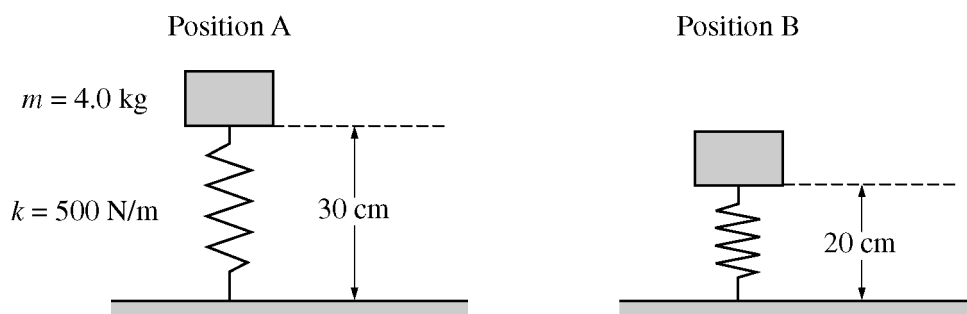

39. A person holds a 4.0 kg block at position A shown above on the left, in contact with an uncompressed vertical spring with a spring constant of 500 N/m. The person gently lowers the block from rest at position A to rest at position B. Which of the following describes the change in the energy of the block-spring-Earth system as a result of the block being lowered?
- (A) The energy decreases by approximately 1.5 J.
 - (B) The energy decreases by approximately 2.5 J.
 - (C) The energy increases by approximately 4.0 J.
 - (D) The energy of the system does not change.

GO ON TO THE NEXT PAGE.

Questions 40-42 refer to the following material.

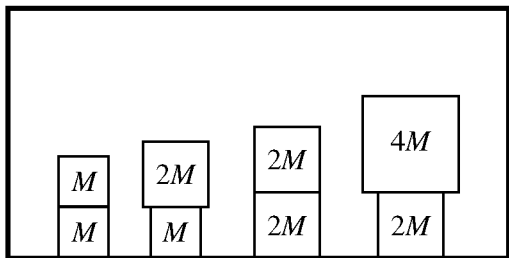

The stacks of boxes shown in the figure above are inside an elevator that is moving upward. The masses of the boxes are given in terms of the mass M of the lightest box.

40. How does the magnitude of the force exerted by the top box on the bottom box compare with the magnitude of the force exerted by the bottom box on the top box for each of the stacks?

- (A) The two magnitudes are always equal in each of the stacks.
- (B) The two magnitudes are always different in each of the stacks.
- (C) The two magnitudes are equal when the boxes have equal mass and different when the boxes have different masses.
- (D) The two magnitudes are equal when the elevator is moving at constant speed and different when it is accelerating.

41. Assume the elevator is moving at constant speed, and consider the bottom box in the stack that has two boxes of mass $2M$. Let F_{floor} be the force exerted by the floor on the box, F_g be the force exerted by gravity on the box, and F_{box} be the force exerted by the top box on the bottom box. Which of the following best represents the forces exerted on the bottom box?

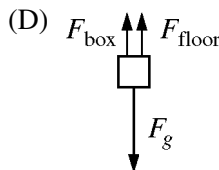
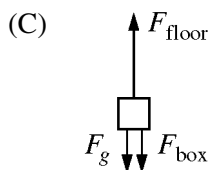
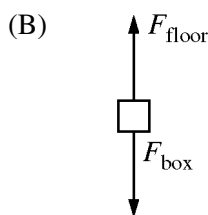
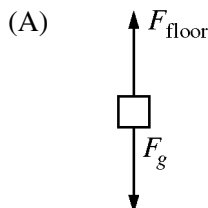

42. Assume the elevator has upward acceleration a , and consider the stack that has two boxes of mass M . What is the magnitude of the force exerted on the top box by the bottom box?

- (A) Mg
- (B) Ma
- (C) $M(a - g)$
- (D) $M(a + g)$

GO ON TO THE NEXT PAGE.

43. A researcher is analyzing data from a high-energy particle collision. The result of the analysis gives a value of $8.8 \times 10^{-19} \text{ C} \pm 0.1 \times 10^{-19} \text{ C}$ for the charge of one of the emitted particles. Should the researcher accept the value?
- (A) Yes, it is a perfectly acceptable value.
 - (B) No, because the value is much bigger than the elementary charge.
 - (C) No, because the value is not an integer multiple of the elementary charge.
 - (D) No, because the uncertainty is more than 1% of the value.

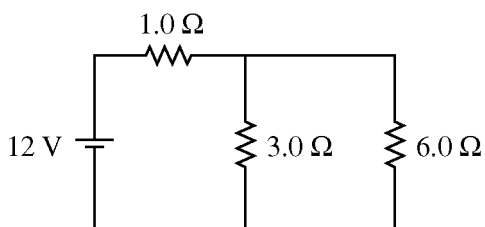

44. The current through the 3Ω resistor in the circuit shown above is most nearly
- (A) 1.3 A
 - (B) 2.7 A
 - (C) 3.0 A
 - (D) 4.0 A

45. A student wants to determine the speed of sound at an elevation of one mile. To do this the student performs an experiment to determine the resonance frequencies of a tube that is closed at one end. The student takes measurements every day for a week and gets different results on different days. Which of the following experiments would help the student determine the reason for the different results?
- (A) Repeating the experiment on several 10°C days and several 20°C days
 - (B) Repeating the experiment using a longer tube
 - (C) Repeating the experiment using a wider range of frequencies of sound
 - (D) Repeating the original experiment for an additional week

GO ON TO THE NEXT PAGE.

Directions: For each of the questions or incomplete statements below, two of the suggested answers will be correct. For each of these questions, you must select both correct choices to earn credit. No partial credit will be earned if only one correct choice is selected. Select the two that are best in each case and then enter both of the appropriate letters in the corresponding space on the answer sheet.

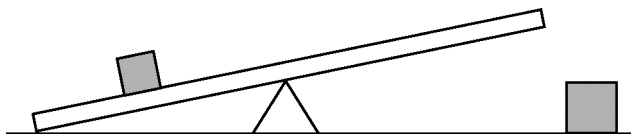

46. A uniform plank is placed with a pivot at its center. A block is placed on the plank to the left of the pivot, as shown in the figure above. A student is asked to place a second block of greater mass on the plank so it will balance when horizontal. Which of the following quantities are needed to determine where the second block should be placed? Select two answers.

- (A) The mass of the plank
- (B) The mass of each block
- (C) The length of the plank
- (D) The distance from the pivot to the left block

GO ON TO THE NEXT PAGE.

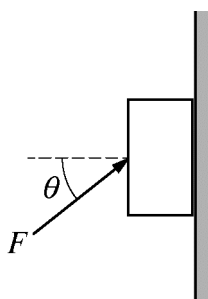

47. A block is held at rest against a wall by a force of magnitude F exerted at an angle θ from the horizontal, as shown in the figure above. Let \vec{F}_g be the gravitational force exerted by Earth on the block, \vec{F}_N be the normal force exerted by the wall on the block, and \vec{F}_f be the frictional force exerted by the wall on the block. Which of the following statements about the magnitudes of the forces on the block must be true? Select two answers.

- (A) $F = F_g / \sin \theta$
- (B) $F \cos \theta = F_N$
- (C) $F \sin \theta = F_g \pm F_f$
- (D) $F = F_g + F_N \pm F_f$

48. Some students have determined the gravitational mass of an object and want to compare it to the object's inertial mass. Procedures that would allow them to accomplish this include which of the following? Select two answers.

- (A) Hanging the object vertically from a spring scale and recording the scale reading
- (B) Placing the object on one side of a double pan balance, adding objects of known mass to the other side until the masses are balanced, and recording the amount of mass added
- (C) Attaching the object to a spring of known spring constant, allowing it to oscillate horizontally on a nearly frictionless surface, and measuring the period
- (D) Attaching the object to a force sensor, using the sensor to pull the object across a nearly frictionless horizontal surface, and measuring the acceleration

GO ON TO THE NEXT PAGE.

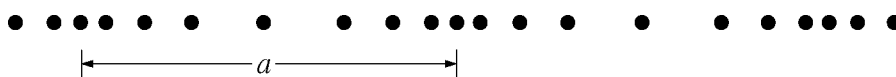

49. The figure above shows a representation of a wave traveling in a uniform medium at a particular instant. Correct statements about the wave include which of the following? Select two answers.
- (A) It is a longitudinal wave.
 - (B) Distance a is the wavelength.
 - (C) The number of dots per unit length is the frequency.
 - (D) The largest distance between two successive dots is the amplitude.

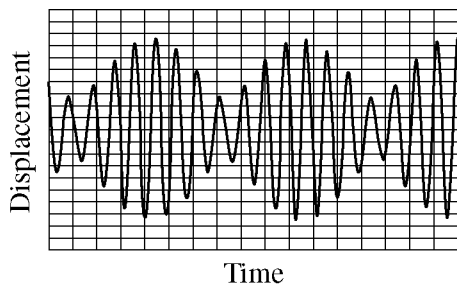

50. A geologist is using a sensor to record waves in a layer of rock and is viewing them on a monitor screen. At one moment the monitor shows the signal above. If the signal is created by just two traveling waves, what can be concluded from the signal about the waves when they reach the sensor? Select two answers.
- (A) The waves have different frequencies.
 - (B) The waves have different amplitudes.
 - (C) The waves are traveling in opposite directions.
 - (D) The waves are traveling at different speeds.

STOP

END OF SECTION I

**IF YOU FINISH BEFORE TIME IS CALLED,
YOU MAY CHECK YOUR WORK ON THIS SECTION.**

DO NOT GO ON TO SECTION II UNTIL YOU ARE TOLD TO DO SO.

AP[®] Physics 1 Practice Exam

SECTION II: Free Response

DO NOT OPEN THIS BOOKLET UNTIL YOU ARE TOLD TO DO SO.

At a Glance

Total Time

90 minutes

Number of Questions

5

Percent of Total Score

50%

Writing Instrument

Either pencil or pen with black or dark blue ink

Electronic Device

Calculator allowed

Suggested Time

Approximately 25 minutes each for questions 2 and 3 and 13 minutes each for questions 1, 4, and 5

Weight

Approximate weights:
Questions 2 and 3:
26% each
Questions 1, 4, and 5:
16% each

IMPORTANT Identification Information

PLEASE PRINT WITH PEN:

1. First two letters of your last name

First letter of your first name

2. Date of birth

Month Day Year

3. Six-digit school code

4. Unless I check the box below, I grant the College Board the unlimited right to use, reproduce, and publish my free-response materials, both written and oral, for educational research and instructional purposes. My name and the name of my school will not be used in any way in connection with my free-response materials. I understand that I am free to mark "No" with no effect on my score or its reporting.

No, I do not grant the College Board these rights.

Instructions

The questions for Section II are printed in this booklet. You may use any blank space in the booklet for scratch work, but you must write your answers in the spaces provided for each answer. A table of information and lists of equations that may be helpful are in the booklet. Calculators, rulers, and straightedges may be used in this section.

All final numerical answers should include appropriate units. Credit for your work depends on demonstrating that you know which physical principles would be appropriate to apply in a particular situation. Therefore, you should show your work for each part in the space provided after that part. If you need more space, be sure to clearly indicate where you continue your work. Credit will be awarded only for work that is clearly designated as the solution to a specific part of a question. Credit also depends on the quality of your solutions and explanations, so you should show your work.

Write clearly and legibly. Cross out any errors you make; erased or crossed-out work will not be scored. You may lose credit for incorrect work that is not crossed out.

Manage your time carefully. You may proceed freely from one question to the next. You may review your responses if you finish before the end of the exam is announced.

NO TEST MATERIAL ON THIS PAGE

AP[®] PHYSICS 1 TABLE OF INFORMATION

CONSTANTS AND CONVERSION FACTORS

Proton mass, $m_p = 1.67 \times 10^{-27}$ kg Neutron mass, $m_n = 1.67 \times 10^{-27}$ kg Electron mass, $m_e = 9.11 \times 10^{-31}$ kg Speed of light, $c = 3.00 \times 10^8$ m/s	Electron charge magnitude, $e = 1.60 \times 10^{-19}$ C Coulomb's law constant, $k = 1/4\pi\epsilon_0 = 9.0 \times 10^9$ N·m ² /C ² Universal gravitational constant, $G = 6.67 \times 10^{-11}$ m ³ /kg·s ² Acceleration due to gravity at Earth's surface, $g = 9.8$ m/s ²
---	--

UNIT SYMBOLS	meter, m	kelvin, K	watt, W	degree Celsius, °C
	kilogram, kg	hertz, Hz	coulomb, C	
	second, s	newton, N	volt, V	
	ampere, A	joule, J	ohm, Ω	

PREFIXES		
Factor	Prefix	Symbol
10^{12}	tera	T
10^9	giga	G
10^6	mega	M
10^3	kilo	k
10^{-2}	centi	c
10^{-3}	milli	m
10^{-6}	micro	μ
10^{-9}	nano	n
10^{-12}	pico	p

VALUES OF TRIGONOMETRIC FUNCTIONS FOR COMMON ANGLES							
θ	0°	30°	37°	45°	53°	60°	90°
$\sin \theta$	0	1/2	3/5	$\sqrt{2}/2$	4/5	$\sqrt{3}/2$	1
$\cos \theta$	1	$\sqrt{3}/2$	4/5	$\sqrt{2}/2$	3/5	1/2	0
$\tan \theta$	0	$\sqrt{3}/3$	3/4	1	4/3	$\sqrt{3}$	∞

The following conventions are used in this exam.

- I. The frame of reference of any problem is assumed to be inertial unless otherwise stated.
- II. Assume air resistance is negligible unless otherwise stated.
- III. In all situations, positive work is defined as work done on a system.
- IV. The direction of current is conventional current: the direction in which positive charge would drift.
- V. Assume all batteries and meters are ideal unless otherwise stated.

AP® PHYSICS 1 EQUATIONS

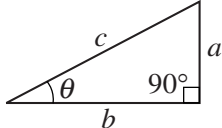
MECHANICS	ELECTRICITY		
$v_x = v_{x0} + a_x t$ $x = x_0 + v_{x0} t + \frac{1}{2} a_x t^2$ $v_x^2 = v_{x0}^2 + 2a_x(x - x_0)$ $\vec{a} = \frac{\sum \vec{F}}{m} = \frac{\vec{F}_{net}}{m}$ $ \vec{F}_f \leq \mu \vec{F}_n $ $a_c = \frac{v^2}{r}$ $\vec{p} = m\vec{v}$ $\Delta\vec{p} = \vec{F} \Delta t$ $K = \frac{1}{2} m v^2$ $\Delta E = W = F_{\parallel} d = F d \cos \theta$ $P = \frac{\Delta E}{\Delta t}$ $\theta = \theta_0 + \omega_0 t + \frac{1}{2} \alpha t^2$ $\omega = \omega_0 + \alpha t$ $x = A \cos(2\pi f t)$ $\vec{\alpha} = \frac{\sum \vec{\tau}}{I} = \frac{\vec{\tau}_{net}}{I}$ $\tau = r_{\perp} F = r F \sin \theta$ $L = I \omega$ $\Delta L = \tau \Delta t$ $K = \frac{1}{2} I \omega^2$ $ \vec{F}_s = k \vec{x} $ $U_s = \frac{1}{2} k x^2$ $\rho = \frac{m}{V}$	$a = \text{acceleration}$ $A = \text{amplitude}$ $d = \text{distance}$ $E = \text{energy}$ $f = \text{frequency}$ $F = \text{force}$ $I = \text{rotational inertia}$ $K = \text{kinetic energy}$ $k = \text{spring constant}$ $L = \text{angular momentum}$ $\ell = \text{length}$ $m = \text{mass}$ $P = \text{power}$ $p = \text{momentum}$ $r = \text{radius or separation}$ $T = \text{period}$ $t = \text{time}$ $U = \text{potential energy}$ $V = \text{volume}$ $v = \text{speed}$ $W = \text{work done on a system}$ $x = \text{position}$ $y = \text{height}$ $\alpha = \text{angular acceleration}$ $\mu = \text{coefficient of friction}$ $\theta = \text{angle}$ $\rho = \text{density}$ $\tau = \text{torque}$ $\omega = \text{angular speed}$ $\Delta U_g = m g \Delta y$ $T = \frac{2\pi}{\omega} = \frac{1}{f}$ $T_s = 2\pi \sqrt{\frac{m}{k}}$ $T_p = 2\pi \sqrt{\frac{\ell}{g}}$ $ \vec{F}_g = G \frac{m_1 m_2}{r^2}$ $\vec{g} = \frac{\vec{F}_g}{m}$ $U_G = -\frac{G m_1 m_2}{r}$		
	$ \vec{F}_E = k \left \frac{q_1 q_2}{r^2} \right $ $I = \frac{\Delta q}{\Delta t}$ $R = \frac{\rho \ell}{A}$ $I = \frac{\Delta V}{R}$ $P = I \Delta V$ $R_s = \sum_i R_i$ $\frac{1}{R_p} = \sum_i \frac{1}{R_i}$ $A = \text{area}$ $F = \text{force}$ $I = \text{current}$ $\ell = \text{length}$ $P = \text{power}$ $q = \text{charge}$ $R = \text{resistance}$ $r = \text{separation}$ $t = \text{time}$ $V = \text{electric potential}$ $\rho = \text{resistivity}$		
	WAVES		
	$\lambda = \frac{v}{f}$ $f = \text{frequency}$ $v = \text{speed}$ $\lambda = \text{wavelength}$		
	GEOMETRY AND TRIGONOMETRY		
	<table style="width: 100%; border: none;"> <tr> <td style="width: 50%; vertical-align: top;"> <p>Rectangle $A = bh$</p> <p>Triangle $A = \frac{1}{2} bh$</p> <p>Circle $A = \pi r^2$ $C = 2\pi r$</p> <p>Rectangular solid $V = \ell wh$</p> <p>Cylinder $V = \pi r^2 \ell$ $S = 2\pi r \ell + 2\pi r^2$</p> <p>Sphere $V = \frac{4}{3} \pi r^3$ $S = 4\pi r^2$</p> </td> <td style="width: 50%; vertical-align: top;"> <p>$A = \text{area}$ $C = \text{circumference}$ $V = \text{volume}$ $S = \text{surface area}$ $b = \text{base}$ $h = \text{height}$ $\ell = \text{length}$ $w = \text{width}$ $r = \text{radius}$</p> <p>Right triangle $c^2 = a^2 + b^2$ $\sin \theta = \frac{a}{c}$ $\cos \theta = \frac{b}{c}$ $\tan \theta = \frac{a}{b}$</p> </td> </tr> </table>	<p>Rectangle $A = bh$</p> <p>Triangle $A = \frac{1}{2} bh$</p> <p>Circle $A = \pi r^2$ $C = 2\pi r$</p> <p>Rectangular solid $V = \ell wh$</p> <p>Cylinder $V = \pi r^2 \ell$ $S = 2\pi r \ell + 2\pi r^2$</p> <p>Sphere $V = \frac{4}{3} \pi r^3$ $S = 4\pi r^2$</p>	<p>$A = \text{area}$ $C = \text{circumference}$ $V = \text{volume}$ $S = \text{surface area}$ $b = \text{base}$ $h = \text{height}$ $\ell = \text{length}$ $w = \text{width}$ $r = \text{radius}$</p> <p>Right triangle $c^2 = a^2 + b^2$ $\sin \theta = \frac{a}{c}$ $\cos \theta = \frac{b}{c}$ $\tan \theta = \frac{a}{b}$</p>
<p>Rectangle $A = bh$</p> <p>Triangle $A = \frac{1}{2} bh$</p> <p>Circle $A = \pi r^2$ $C = 2\pi r$</p> <p>Rectangular solid $V = \ell wh$</p> <p>Cylinder $V = \pi r^2 \ell$ $S = 2\pi r \ell + 2\pi r^2$</p> <p>Sphere $V = \frac{4}{3} \pi r^3$ $S = 4\pi r^2$</p>	<p>$A = \text{area}$ $C = \text{circumference}$ $V = \text{volume}$ $S = \text{surface area}$ $b = \text{base}$ $h = \text{height}$ $\ell = \text{length}$ $w = \text{width}$ $r = \text{radius}$</p> <p>Right triangle $c^2 = a^2 + b^2$ $\sin \theta = \frac{a}{c}$ $\cos \theta = \frac{b}{c}$ $\tan \theta = \frac{a}{b}$</p>		
			

PHYSICS 1
Section II
5 Questions
Time—90 minutes

Directions: Questions 2 and 3 are long free-response questions that require about 25 minutes each to answer and are worth 12 points each. Questions 1, 4, and 5 are short free-response questions that require about 13 minutes each to answer and are worth 7 points each. Show your work for each part in the space provided after that part.

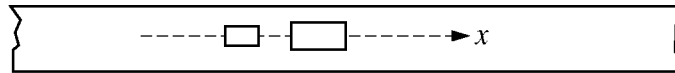

Top View

1. (7 points, suggested time about 13 minutes)

The figure above represents two carts, with magnets attached, that make up a system. The mass of one cart and magnet is 1 kg and the mass of the other is 5 kg. The carts are initially at rest on a frictionless track. They are released from rest and exert a repulsive force on each other. The track is not quite horizontal, with the right side slightly lower than the left side.

The speeds of the carts are measured over a 10 s interval. The graph below shows the momentum of the two carts as a function of time for this interval as they move along the x -axis.

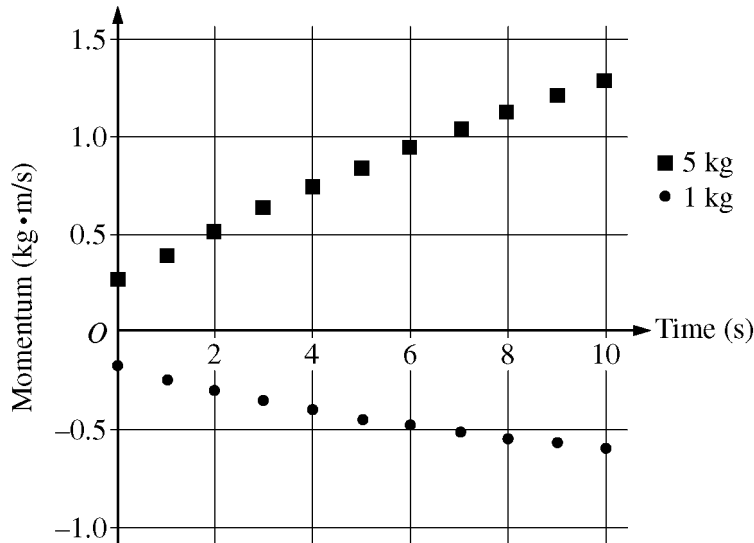

GO ON TO THE NEXT PAGE.

(a) Based on the graph, were the measurements started at the instant the carts were released?

Justify your answer.

(b) Calculate the magnitude of the external force exerted on the system.

(c) Suppose the experiment is repeated with different carts, so that the masses of cart plus magnet are 2 kg and 4 kg. Would your answer to part (b) be different with the new masses?

Justify your answer.

GO ON TO THE NEXT PAGE.

2. (12 points, suggested time 25 minutes)

A student hangs a 0.125 kg object on a spring, sets it into oscillation, and obtains the data for the position and velocity of the object as a function of time shown in the graphs below.

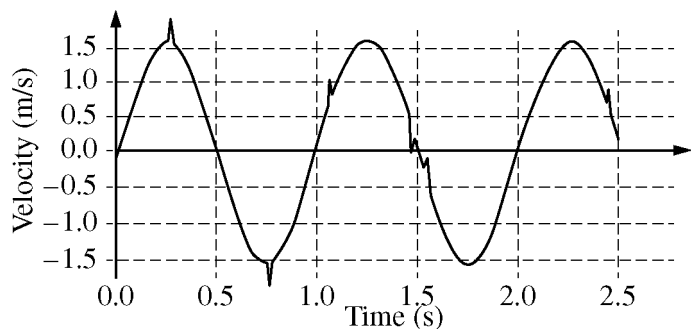
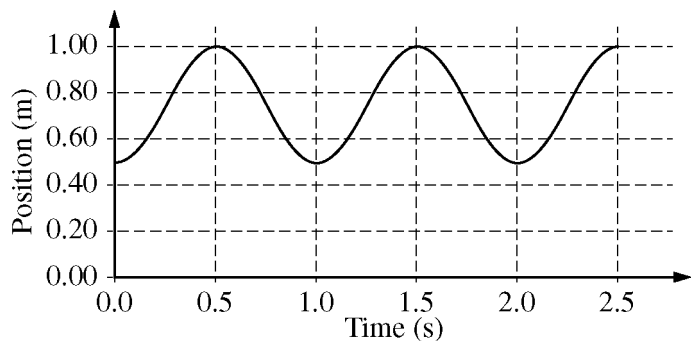

(a) On the grid below, sketch the potential energy of the object-spring-Earth system as a function of time. Explicitly label any intercepts, asymptotes, maxima, or minima with numerical values, as appropriate.

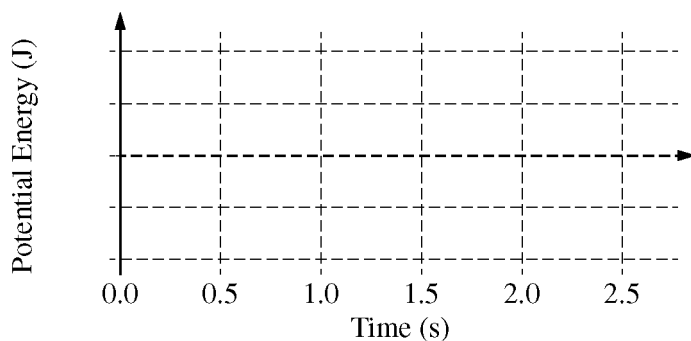

(b) On the axes below, sketch the acceleration of the object as a function of time. Explicitly label any intercepts, asymptotes, maxima, or minima with numerical values, as appropriate.

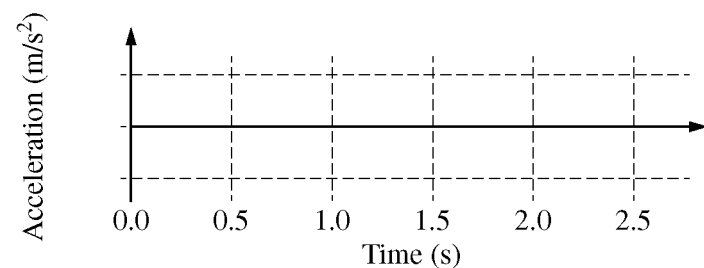

GO ON TO THE NEXT PAGE.

Next the student is given a rubber band and asked to determine whether the relationship between the restoring force exerted by the rubber band and the amount it is stretched is the same as that of an ideal spring.

(c) Describe an experimental procedure that the student could use to collect the necessary data, including all the equipment the student would need.

(d) How should the student analyze the data to determine whether the relationship between the restoring force exerted by the rubber band and the amount it is stretched is the same as that of an ideal spring? What evidence from the analysis would be used to make the determination?

GO ON TO THE NEXT PAGE.

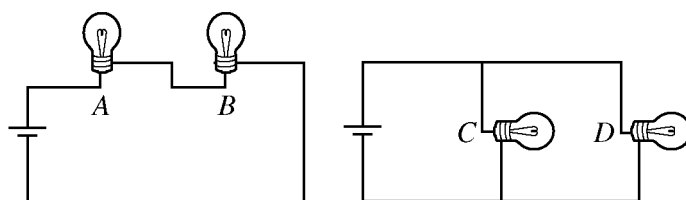

3. (12 points, suggested time 25 minutes)

In a physics lab, students will compare the two circuits shown above. In one circuit, lightbulbs *A* and *B* will be connected to a battery in series. In the other circuit, lightbulbs *C* and *D* will be connected to an identical battery in parallel. All four lightbulbs are identical.

Student 1 predicts that the bulbs will be brighter in the series arrangement, while Student 2 disagrees and predicts that the bulbs will be brighter in the parallel arrangement. Their arguments are as follows.

Student 1: “Bulbs *A* and *B* will be brighter than *C* and *D* because in the series circuit, each bulb gets all the current coming out of the battery. But in the parallel circuit each bulb gets only half the current.”

Student 2: “But you’re not taking into account that bulb *A* uses up some of the current before it reaches bulb *B*, making the bulbs dimmer in the series circuit. And in the parallel circuit, the full voltage of the battery is across each bulb, so it’s as if the other bulb weren’t even there. So bulbs *C* and *D* will be brighter.”

(a) For part (a), ignore whether the students’ predictions are correct or incorrect. Do not simply repeat the students’ arguments as your answers.

i. Which aspects of Student 1’s reasoning, if any, are correct? Explain your answer.

ii. Which aspects of Student 1’s reasoning, if any, are incorrect? Explain your answer.

iii. Which aspects of Student 2’s reasoning, if any, are correct? Explain your answer.

iv. Which aspects of Student 2’s reasoning, if any, are incorrect? Explain your answer.

GO ON TO THE NEXT PAGE.

Together the students write the following equations to describe the two circuits.

Series Arrangement

Equation 1: $I_S = I_A = I_B$

Equation 2: $\Delta V - I_A R_A - I_B R_B = 0$

Parallel Arrangement

Equation 3: $I_P = I_C + I_D$

Equation 4: $\Delta V - I_C R_C = \Delta V - I_D R_D = 0$

(b)

i. Indicate all of the equations above that support Student 1's reasoning, and explain how each equation provides support.

ii. Indicate all of the equations above that support Student 2's reasoning, and explain how each equation provides support.

(c) Resolve the two lines of reasoning about the two circuits to conclude which arrangement will have brighter bulbs. Use the equations above and any other equations that you need, and explain how the equations support your conclusion.

GO ON TO THE NEXT PAGE.

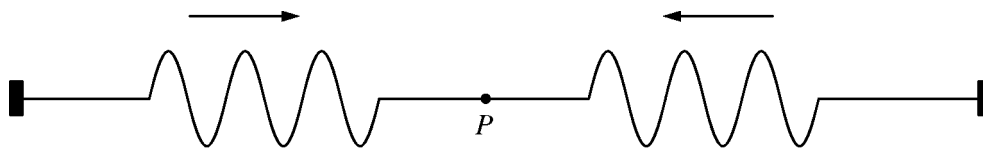

4. (7 points, suggested time about 13 minutes)

A string is held taut, with each of its ends fixed to an oscillator that creates wave pulses on the string. The figure above shows identical pulses at a particular instant when they are traveling toward each other on the string. The pulses have wavelength λ and amplitude A , and are equidistant from point P .

(a) On the figure below, the dashed line at zero displacement represents the string with no pulses. On the figure, draw the shape of the string at the instant when the pulses overlap by $1/3$ of the length of each pulse.

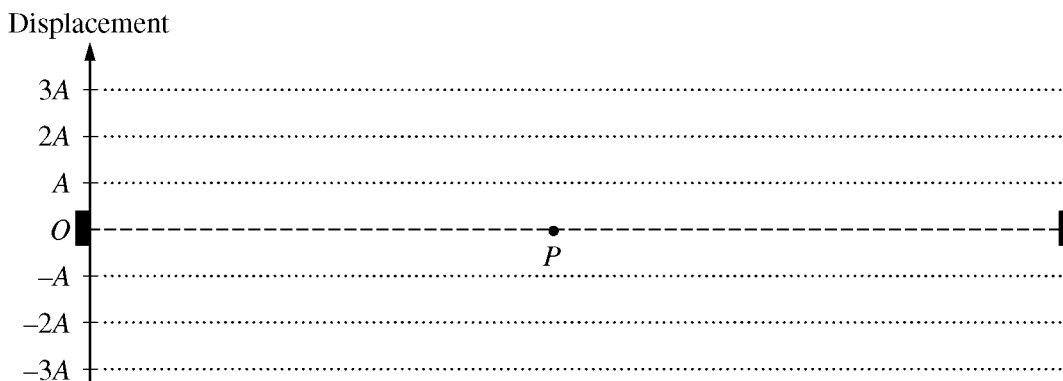

(b) On the axes below, sketch a graph of displacement as a function of time for point P , from time $t = 0$ when the pulses just begin to overlap until $t = t_1$ when they once again do not overlap.



(c) Next the oscillators are adjusted to create continuous waves of wavelength λ , instead of the wave pulses shown. A standing wave is created on the string. What can be inferred about the length of the string? Justify your answer. Equations may be part of your reasoning, but equations alone are not sufficient justification.

GO ON TO THE NEXT PAGE.

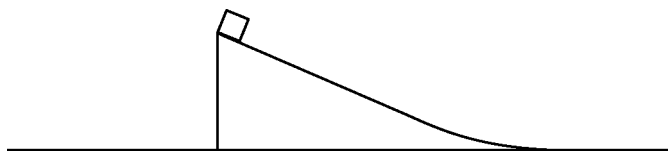

5. (7 points, suggested time about 13 minutes)

The figure above shows part of a system consisting of a block at the top of an inclined plane that rests on a table, which is located on Earth. The block and plane are at rest when the block is released. In trial 1 there is no friction between the block and the plane or between the plane and the table. In trial 2 the plane is fixed to the table so it cannot move, but there is still no friction between the block and the plane.

Indicate whether the speed of the block relative to the table when the block reaches the bottom of the plane is greater in trial 1 or trial 2. Justify your answer in a clear, coherent, paragraph-length explanation.

GO ON TO THE NEXT PAGE.

S T O P

END OF EXAM

**IF YOU FINISH BEFORE TIME IS CALLED,
YOU MAY CHECK YOUR WORK ON THIS SECTION.**



Notes on the Practice Exam

Introduction

This section provides a description of how the questions in the AP Physics 1 Practice Exam correspond to the components of the curriculum framework included in the *AP[®] Physics 1: Algebra-Based* and *AP[®] Physics 2: Algebra-Based Course and Exam Description*. For each of the questions in the AP Practice Exam, the essential knowledge, science practices, and targeted learning objectives from the curriculum framework are indicated.

In addition, the multiple-choice and free-response questions include the following features:

- For multiple-choice questions, the correct response is indicated with a justification for why it is correct. There are additional explanations that address why the other responses are incorrect.
- Free-response questions include scoring guidelines as well as descriptions of student responses that would represent “strong, good, and weak” levels. These scoring guidelines demonstrate how the essential knowledge and application of the science practices are assessed in each free-response question.

The 2015 AP Physics 1 Exam is approximately 3 hours in length. There are two sections, each accounting for 50 percent of the student’s exam score.

Section I is 90 minutes long and consists of 50 multiple-choice questions presented as discrete questions or questions in sets. These multiple-choice questions include two question types: single-select questions and multi-select questions having two correct answers (students need to select both correct answers to earn credit). Section I begins with 45 single-select questions, followed directly by five multi-select questions.

Section II is 90 minutes long and consists of five free-response questions of the following types:

- Experimental design — pertains to designing and describing an investigation, analysis of authentic lab data, and observations to identify patterns or explain phenomena
- Qualitative/quantitative translation — requires translating between quantitative and qualitative justification and reasoning
- Short answer questions — one of which will require a paragraph-length coherent argument

Section	Timing	Scoring	Question Type	Number of Questions
I: Multiple Choice	90 minutes	50% of exam score		
			Single-select (discrete questions and questions in sets with one correct answer)	45
			Multi-select (discrete questions with two correct answers)	5
				Total – 50

Section	Timing	Scoring	Question Type	Number of Questions
II: Free Response	90 minutes	50% of exam score		
			Experimental Design	1
			Qualitative/Quantitative Translation	1
			Short-Answer	3
				Total – 5

All of the questions on the exam are designed to measure the student’s understanding of the big ideas, enduring understandings, and essential knowledge, and the student’s application of this understanding through the science practices.

Multiple-Choice Section

In Section I, there are 50 multiple-choice questions. These questions represent the knowledge and skills students should know, understand, and be able to apply.

Students will be allowed to use a calculator on the entire AP Physics 1 exam — including both the multiple-choice and free-response sections. Tables containing equations commonly used in physics will be provided for students to use during the entire AP Physics 1 exam.

Information for Multiple-Choice Questions 1–50

Question 1

Essential Knowledge	3.E.1 The change in the kinetic energy of an object depends on the force exerted on the object and on the displacement of the object during the time interval that the force is exerted.
Science Practice	1.4 The student can use representations and models to analyze situations or solve problems qualitatively and quantitatively.
Learning Objective	3.E.1.2 The student is able to use net force and velocity vectors to determine qualitatively whether kinetic energy of an object would increase, decrease, or remain unchanged.
(A)	This option is incorrect. A force exerted perpendicular to the direction of motion changes the direction of the object's motion but does not change the object's speed.
(B)	This option is incorrect. A force directed “backwards” compared to the object's motion — in this case a leftward force exerted on an object moving to the right — slows down the object but does not change its direction of motion.
(C)	This option is incorrect. The object does indeed change direction, because the force is not parallel or antiparallel to the direction of motion, but a component of the force points in the direction of motion (rightward), making the object speed up, not slow down.
(D)	This option is correct. Break the force direction into components parallel and perpendicular to the object's motion. The leftward parallel component points backwards compared to the velocity, so the object slows down. And the perpendicular (up-the-page) component changes the object's direction of motion.

Question 2

Essential Knowledge	5.B.4 The internal energy of a system includes the kinetic energy of the objects that make up the system and the potential energy of the configuration of the objects that make up the system.
Science Practice	6.4 The student can make claims and predictions about natural phenomena based on scientific theories and models.
Learning Objective	5.B.4.1 The student is able to describe and make predictions about the internal energy of systems.
(A)	This option is correct. Mechanical energy stays constant during the ball's swing. During each segment, the kinetic energy gained by the ball equals the gravitational potential energy lost by the ball/Earth system. Between 1 and 2, the ball loses the most height, and hence, the system loses the most gravitational potential energy ($\Delta U_{grav} = mg\Delta y$).
(B)	This option is incorrect. Although the ball travels the same distance from 2 to 3 as it traveled from 1 to 2, the ball "falls" through less <i>vertical</i> distance between 2 and 3. The system loses less gravitational potential energy between 2 and 3 than it did between 1 and 2, and therefore gains less kinetic energy.
(C)	This option is incorrect. The ball loses much less height (vertical distance) between 3 and 4 than it did between 1 and 2. Therefore it loses less potential energy — and gains less kinetic energy — between 3 and 4.
(D)	This option is incorrect. During each successive segment, the ball loses less height and hence the system loses less gravitational potential energy. Therefore, over each successive segment, the ball gains less kinetic energy.

Question 3

Essential Knowledge	2.B.2 The gravitational field caused by a spherically symmetric object with mass is radial and, outside the object, varies as the inverse square of the radial distance from the center of that object.
Science Practices	2.2 The student can apply mathematical routines to quantities that describe natural phenomena.
Learning Objective	2.B.2.2 The student is able to approximate a numerical value of the gravitational field (g) near the surface of an object from its radius and mass relative to those of the Earth or other reference objects.
(A)	This option is incorrect. This would be correct if the new planet's mass were two-thirds of the Earth's mass and its radius were twice the Earth's. But because the new planet has twice the Earth's radius, its volume is eight times larger than Earth's. "Filling" that larger volume results in a planet more massive than Earth, though less dense.
(B)	This option is incorrect. Other things being equal, doubling the radius of the planet would reduce the gravitational field at its surface by a factor of 4, not a factor of 2. Doubling its radius also increases its mass, as explained in (A).
(C)	This option is incorrect. If the new planet differed from Earth <i>only</i> in having two-thirds the density, then its mass would be two-thirds of Earth's and hence its gravitational field would be two-thirds of Earth's, about 6.7 m/s^2 . But the new planet is also bigger than Earth.
(D)	This option is correct. Other things being equal, doubling a planet's radius would cut the gravitational field to one-fourth, due to the square in $g = F_{grav}/m = GM/r^2$. But the new planet also has more mass than Earth. Doubling the radius increases the volume by a factor of 8; but this does not mean the mass increases by 8 times, because the planet's density is two-thirds that of Earth. Instead, the new planet's mass is two-thirds of 8 times the Earth's, i.e., $2/3 * 8 = 5.3$ times the mass of Earth. Taking both mass and radius into account, the new planet's g is $(5.3)/4$ times the Earth's: $9.8 \text{ m/s}^2 * (5.3)/4 = 13 \text{ N/kg}$.

Question 4

Essential Knowledge	3.A.3 A force exerted on an object is always due to the interaction of that object with another object. 3.B.2 Free-body diagrams are useful tools for visualizing forces being exerted on a single object and writing the equations that represent a physical situation.
Science Practice	1.4 The student can use representations and models to analyze situations or solve problems qualitatively and quantitatively. 6.4 The student can make claims and predictions about natural phenomena based on scientific theories and models.
Learning Objective	3.A.3.1 The student is able to analyze a scenario and make claims (develop arguments, justify assertions) about the forces exerted on an object by other objects for different types of forces or components of forces. 3.B.2.1 The student is able to create and use free-body diagrams to analyze physical situations to solve problems with motion qualitatively and quantitatively.
(A)	This option is incorrect. The box slides to the right with respect to the bus, but not because a rightward (eastward) force is exerted on the box. The box's inertia is what leads it to slide rightward with respect to the bus: Because the bus starts gaining westward velocity while the box's velocity initially keeps it moving purely northward, the bus is moving westward relative to the box. Therefore, the box is moving eastward (to the right) relative to the bus.
(B)	This option is correct. While the box slides rightward relative to the bus (see explanation A), the floor of the bus exerts a frictional force that opposes the box's motion — a force directed to the left.
(C)	This option is incorrect. The box initially retains its northward velocity, but not because a northward force acts on it. Once it is already moving northward, the box's inertia keeps it moving northward (Newton's 1 st law).
(D)	This option is incorrect. As explained in (A) above, no rightward force is exerted on the box.

Question 5

<p>Essential Knowledge</p>	<p>3.B.1 If an object of interest interacts with several other objects, the net force is the vector sum of the individual forces. 5.B.4 The internal energy of a system includes the kinetic energy of the objects that make up the system and the potential energy of the configuration of the objects that make up the system.</p>
<p>Science Practice</p>	<p>6.4 The student can make claims and predictions about natural phenomena based on scientific theories and models. 7.2 The student can connect concepts in and across domain(s) to generalize or extrapolate in and/or across enduring understandings and/or big ideas.</p>
<p>Learning Objective</p>	<p>3.B.1.1 The student is able to predict the motion of an object subject to forces exerted by several objects using an application of Newton's Second Law in a variety of physical situations with acceleration in one dimension. 5.B.4.1 The student is able to describe and make predictions about the internal energy of systems.</p>
<p>(A)</p>	<p>This option is incorrect. Because no force opposes the gravitational force exerted on the block, it has the “full” free-fall acceleration of 9.8 m/s^2 and it also has the shortest distance to travel.</p>
<p>(B)</p>	<p>This option is correct. Block B arrives at the ground with just as much <i>speed</i> as block A. But block B takes more <i>time</i> to reach the ground, for two reasons. First, B covers more distance than A. Second, B has a smaller acceleration, because the normal force exerted by the ramp partially opposes the downward force exerted by gravity on B.</p>
<p>(C)</p>	<p>This option is incorrect. Block C lands just as quickly as block A. Although C covers more total distance, both blocks start with the same <i>vertical</i> velocity ($v_{0y} = 0$) and cover the same <i>vertical</i> distance ($\Delta y = h$) with the same <i>vertical</i> acceleration ($a_y = g$). Therefore, they take the same time. The horizontal motion of C has no effect on its vertical motion.</p>
<p>(D)</p>	<p>This option is incorrect. As explained above, A and C land at the same time, but B takes more time to reach the ground.</p>

Question 6

<p>Essential Knowledge</p>	<p>3.B.1 If an object of interest interacts with several other objects, the net force is the vector sum of the individual forces. 5.B.4 The internal energy of a system includes the kinetic energy of the objects that make up the system and the potential energy of the configuration of the objects that make up the system.</p>
<p>Science Practice</p>	<p>6.4 The student can make claims and predictions about natural phenomena based on scientific theories and models. 7.2 The student can connect concepts in and across domain(s) to generalize or extrapolate in and/or across enduring understandings and/or big ideas.</p>
<p>Learning Objective</p>	<p>3.B.1.1 The student is able to predict the motion of an object subject to forces exerted by several objects using an application of Newton's second law in a variety of physical situations with acceleration in one dimension. 5.B.4.1 The student is able to describe and make predictions about the internal energy of system.</p>
<p>(A)</p>	<p>This option is incorrect. Because blocks A and C start with the same vertical velocity ($v_{0y} = 0$) and fall through the same <i>vertical</i> distance ($\Delta y = h$) with the same <i>vertical</i> acceleration ($a_y = g$), they end up with the same <i>vertical</i> velocity. But block C, unlike block A, has <i>horizontal</i> velocity as well. So, block A ends up with less overall speed (just before hitting the ground).</p>
<p>(B)</p>	<p>This option is incorrect. Blocks A and B reach the ground with the same kinetic energy and hence the same speed. This is because they both start at rest, and both block-Earth systems lose the same potential energy ($\Delta U_{grav} = -mgh$) and hence gain the same kinetic energy.</p>
<p>(C)</p>	<p>This option is correct. In all three cases, the same potential energy is lost and hence the same kinetic energy is <i>gained</i>. But block C, unlike A and B, <i>starts</i> with nonzero kinetic energy. This initial kinetic energy adds onto the kinetic energy it gains, giving C the biggest final kinetic energy and therefore the most speed.</p>
<p>(D)</p>	<p>This option is incorrect. As explained in (C), although all three blocks <i>gain</i> the same kinetic energy, block C <i>starts</i> with the most kinetic energy and therefore ends up with the greatest kinetic energy (and therefore speed).</p>

Question 7

Essential Knowledge	5.B.4 The internal energy of a system includes the kinetic energy of the objects that make up the system and the potential energy of the configuration of the objects that make up the system.
Science Practice	1.4 The student can use representations and models to analyze situations or solve problems qualitatively and quantitatively. 2.1 The student can justify the selection of a mathematical routine to solve problems.
Learning Objective	5.B.4.2 The student is able to calculate changes in kinetic energy and potential energy of a system, using information from representations of that system.
(A)	This option is incorrect. The system's potential energy is zero at that point (if we set $y = 0$ at the floor). But the ball is moving upward and therefore has nonzero kinetic energy. Therefore, its mechanical energy ($K + U$) is nonzero.
(B)	This option is incorrect. The system <i>loses</i> 3 J of mechanical energy during the bounce; but that's different from how much mechanical energy the system <i>still has</i> after it bounces.
(C)	This option is correct. After the ball leaves the floor, the system no longer gains or loses mechanical energy as the ball rises to its peak. As it rises, kinetic energy converts to gravitational potential energy, but the mechanical energy ($K + U$) stays the same. As a result, the system has the same mechanical energy immediately after the bounce as it has at the peak.
(D)	This option is incorrect. The system's mechanical energy changes from 10 J to 7 J during the bounce, when some mechanical energy dissipates largely as thermal energy. No mechanical energy dissipates while the ball rises.

Question 8

Essential Knowledge	4.D.1 Torque, angular velocity, angular acceleration, and angular momentum are vectors and can be characterized as positive or negative depending upon whether they give rise to or correspond to counterclockwise or clockwise rotation with respect to an axis.
Science Practice	1.2 The student can describe representations and models of natural or man-made phenomena and systems in the domain. 1.4 The student can use representations and models to analyze situations or solve problems qualitatively and quantitatively.
Learning Objective	4.D.1.1 The student is able to describe a representation and use it to analyze a situation in which several forces exerted on a rotating system of rigidly connected objects change the angular velocity and angular momentum of the system.
(A)	This option is incorrect. Because the question defines counterclockwise as positive, the disk's initial angular velocity is positive; however graph A shows the initial angular velocity as negative.
(B)	This option is incorrect. Because the torques exerted on the disk do not balance, the disk changes angular velocity; however graph B shows the angular velocity as constant.
(C)	This option is correct. The net torque on the disk is constant and oriented clockwise. So, the disk has a constant clockwise angular acceleration. Because counterclockwise is positive, this angular acceleration — the rate of change of the angular velocity — is constant and negative.
(D)	This option is incorrect. It correctly shows the disk's angular <i>speed</i> as its counterclockwise angular velocity steadily decreases to zero and then its clockwise angular velocity steadily increases. The angular <i>velocity</i> graph should depict the clockwise and counterclockwise angular velocities as having opposite signs.

Question 9

Essential Knowledge	3.B.1 If an object of interest interacts with several other objects, the net force is the vector sum of the individual forces.
Science Practice	6.4 The student can make claims and predictions about natural phenomena based on scientific theories and models.
Learning Objective	3.B.1.1 The student is able to predict the motion of an object subject to forces exerted by several objects using an application of Newton's second law in a variety of physical situations with acceleration in one dimension.
(A)	This option is correct. The maximum force of static friction that the floor can exert on the box is $\mu_s F_{\text{normal}} = \mu_s F_{\text{grav}} = (0.50)(50.0 \text{ N}) = 25 \text{ N}$. Therefore, the 20.0 N horizontal force exerted on the box cannot overcome the static frictional force, and the box remains at rest.
(B)	This option is incorrect. The 0.50 coefficient of static friction does not necessarily equal the box's acceleration.
(C)	This option is incorrect. If the box were moving, the frictional force exerted on it would be $(0.30)F_{\text{normal}} = 15 \text{ N}$, and hence the net horizontal force would be $20 \text{ N} - 15 \text{ N} = 5 \text{ N}$, causing an acceleration of about 1 m/s^2 . As explained in (A), however, the force of static friction prevents the block from moving.
(D)	This option is incorrect. If no frictional force were exerted on the block, then the net force would be 20.0 N, causing the box to accelerate at about 4 m/s^2 . But the net horizontal force includes a frictional force.

Question 10

Essential Knowledge	3.E.3 A torque exerted on an object can change the angular momentum of an object.
Science Practice	6.4 The student can make claims and predictions about natural phenomena based on scientific theories and models. 7.2 The student can connect concepts in and across domain(s) to generalize or extrapolate in and/or across enduring understandings and/or big idea.
Learning Objective	3.E.3.1 The student is able to predict the behavior of rotational collision situations by the same processes that are used to analyze linear collision situations using an analogy between impulse and change of linear momentum and angular impulse and change of angular momentum.
(A)	This option is incorrect. If the given initial momentum were expressed as a negative number, then $P_f - P_i$ would give the sphere's change in linear momentum. However the sphere's change in linear momentum cannot be equated to the rod's change in angular momentum.
(B)	This option is incorrect. $P_f + P_i$ is the ball's change in linear momentum. This cannot be equated to the rod's change in <i>angular</i> momentum, because linear and angular momenta are different physical quantities (as indicated by their different units).
(C)	This option is incorrect. If the given initial momentum were expressed as a negative number, then this would be the magnitude of the sphere's — and hence the rod's — change in angular momentum. But the given linear momenta are both magnitudes.
(D)	This option is correct. Because $p = mv$, pd is just another way of expressing mvr, the sphere's angular momentum with respect to the rod's pivot. Therefore, $(p_f + p_i)d$ is the sphere's change in angular momentum. The terms are added because the sphere's overall change in angular momentum is the lost counterclockwise angular momentum $(p_i d)$ plus the gained clockwise momentum $(p_f d)$. Because angular momentum stays constant during the collision, the rod's angular momentum changes by the same amount.

Question 11

Essential Knowledge	3.C.1 Gravitational force describes the interaction of one object that has mass with another object that has mass.
Science Practice	2.2 The student can apply mathematical routines to quantities that describe natural phenomena.
Learning Objective	3.C.1.2 The student is able to use Newton's law of gravitation to calculate the gravitational force between two objects and use that force in contexts involving orbital motion (for circular orbital motion only in Physics 1).
(A)	This option is incorrect. The distance of the spacecraft from the center of the planet is needed, but only the altitude above the surface is given.
(B)	This option is correct. Orbital velocity is found by equating gravitational force from Newton's law of gravitation with the product of spacecraft mass and centripetal acceleration, and solving for velocity. The result depends only on G, planet mass and distance from the center of the planet. Because height above the surface is given, the planet radius is also needed to find the orbit radius.
(C)	This option is incorrect. Because gravitational mass and inertial mass are equal, the spacecraft mass cancels in the solution.
(D)	This option is incorrect. The planet's radius is needed to calculate the orbit radius, but the spacecraft mass will cancel.

Question 12

Essential Knowledge	4.B.1 The change in linear momentum for a constant-mass system is the product of the mass of the system and the change in velocity of the center of mass.
Science Practice	1.4 The student can use representations and models to analyze situations or solve problems qualitatively and quantitatively. 2.2 The student can apply mathematical routines to quantities that describe natural phenomena.
Learning Objective	4.B.1.1 The student is able to calculate the change in linear momentum of a two-object system with constant mass in linear motion from a representation of the system (data, graphs, etc.).
(A)	This option is incorrect. It shows a constant negative momentum for the cart of mass m before and after the collision. Momentum conservation of a system can be misinterpreted to mean that momentum of an object is always the same.
(B)	This option incorrect. It has the correct relative magnitudes of the momentum of the cart of mass m before and after the collision but the cart still moving to the left. The “backward” change in momentum of the cart could be confused with a negative sign for direction.
(C)	This option is correct. By momentum conservation, $2mv - mv = mv = (3m)(v/3)$, so carts after collision move with speed $v/3$ to the right. Thus momentum of the cart of mass m before collision is $-mv$ and after collision is $+mv/3$ as shown in the graph for this option.
(D)	This option is incorrect. It assumes that the cart of mass m would move at speed v to the right after the collision. The final system momentum could be confused with the final momentum of block m .

Question 13

Essential Knowledge	4.A.1 The linear motion of a system can be described by the displacement, velocity, and acceleration of its center of mass.
Science Practice	1.4 The student can use representations and models to analyze situations or solve problems qualitatively and quantitatively. 6.4 The student can make claims and predictions about natural phenomena based on scientific theories and models.
Learning Objective	4.A.1.1 The student is able to use representations of the center of mass of an isolated two-object system to analyze the motion of the system qualitatively and semi-quantitatively.
(A)	This option is incorrect. It shows the motion of the student across the raft driving both the raft and student forward.
(B)	This option is incorrect. It shows the raft remaining at rest while the student walks along it.
(C)	This option is correct. Because the mass of the student and the mass of the raft are the same, the system center of mass must be halfway between the object centers, i.e., at 2.5 divisions from the left edge of the pool. With no external forces the position of the center of mass remains unchanged, so when the student reaches the other end of the raft the new point halfway between the student and the center of the raft must once again be at 2.5 divisions from the left edge of the pool.
(D)	This option is incorrect. It assumes that there is no force between the raft and water, which would result in the student walking over the surface of the raft without moving relative to the pool, and the raft being pushed backward.

Question 14

Essential Knowledge	5.C.3 Kirchhoff's junction rule describes the conservation of electric charge in electrical circuits. Because charge is conserved, current must be conserved at each junction in the circuit. Examples should include circuits that combine resistors in series and parallel. [Physics 1: covers circuits with resistors in series, with at most one parallel branch, one battery only.]
Science Practice	1.4 The student can use representations and models to analyze situations or solve problems qualitatively and quantitatively. 2.2 The student can apply mathematical routines to quantities that describe natural phenomena.
Learning Objective	5.C.3.3 The student is able to use a description or schematic diagram of an electrical circuit to calculate unknown values of current in various segments or branches of the circuit.
(A)	This option is incorrect. It assumes that the current through the battery is split between the resistors in the circuit independent of circuit arrangement.
(B)	This option is incorrect. It assumes that the current through a smaller resistance is larger than that through a larger resistance independent of the circuit arrangement.
(C)	This option is incorrect. It assumes that the current is larger through a larger resistance independent of the circuit arrangement.
(D)	This option is correct. Because all three resistors are connected in series, conservation of charge (Kirchoff's junction rule) requires that the rate of charge transport through all the circuit elements must be the same.

Question 15

Essential Knowledge	3.C.2 Electric force results from the interaction of one object that has an electric charge with another object that has an electric charge.
Science Practice	7.2 The student can connect concepts in and across domain(s) to generalize or extrapolate in and/or across enduring understandings and/or big ideas.
Learning Objective	3.C.2.2 The student is able to connect the concepts of gravitational force and electric force to compare similarities and differences between the forces.
(A)	This option is incorrect. Although the value of the constants is very different, the value has no effect on the behavior of the forces with changing separation between the objects as long as the charges and masses are unchanged.
(B)	This option is incorrect. Although the gravitational force is only attractive, this has no effect on the behavior of the forces as the separation between the objects is changed.
(C)	This option is correct. Both forces have an inverse square dependence. With mass and charge unchanged, the only factor affecting the forces is the change in separation, and each is reduced to $\frac{1}{4}$ of its original value by doubling the separation.
(D)	This option is incorrect. Although the electrostatic force will decrease to one fourth of its value, the magnitude of the two forces depends on the masses of the objects and the net charges on the objects. If those remain unchanged, it is the ratio of the magnitudes of the two forces that will be the same at any given distance.

Question 16

Essential Knowledge	<p>3.D.2 The change in momentum of an object occurs over a time interval.</p> <p>5.D.1 In a collision between objects, linear momentum is conserved. In an elastic collision, kinetic energy is the same before and after.</p>
Science Practice	<p>5.1 The student can analyze data to identify patterns or relationships.</p> <p>6.4 The student can make claims and predictions about natural phenomena based on scientific theories and models.</p>
Learning Objective	<p>5.D.1.2 The student is able to apply the principles of conservation of momentum and restoration of kinetic energy to reconcile a situation that appears to be isolated and elastic, but in which data indicate that linear momentum and kinetic energy are not the same after the interaction, by refining a scientific question to identify interactions that have not been considered. Students will be expected to solve qualitatively and/or quantitatively for one-dimensional situations and only qualitatively in two-dimensional situations.</p> <p>3.D.2.2 The student is able to predict the change in momentum of an object from the average force exerted on the object and the interval of time during which the force is exerted.</p>
(A)	<p>This option is correct. Because the equal-mass balls move with equal speeds in opposite directions initially, the total momentum is zero. Therefore the clay ball and glider, moving together after the collision, must move in the opposite direction as the rubber ball and will move to the right.</p>
(B)	<p>This option is incorrect. The correct reasoning is in terms of momentum, not energy. Also, it is not known whether the collision with the rubber ball is elastic or partially inelastic.</p>
(C)	<p>This option is incorrect. Because (inertial) mass is a measure of an object's inertia, and both balls have the same mass, they have the same inertia. Inertia is not affected by the collision.</p>
(D)	<p>This option is incorrect. It is not known which ball exerts a force for a longer time. Moreover, the relative forces exerted by the balls during the collision would also have to be known in order to reason in terms of collision time.</p>

Question 17

Essential Knowledge	3.A.1 An observer in a particular reference frame can describe the motion of an object using such quantities as position, displacement, distance, velocity, speed, and accelerations.
Science Practice	1.5 The student can re-express key elements of natural phenomena across multiple representations in the domain.
Learning Objective	3.A.1.1 The student is able to express the motion of an object using narrative, mathematical, and graphical representations.
(A)	This option is correct. The graph for the lion shows an initial velocity toward the left, slowing down to zero, and speeding up to the right and reaching a constant velocity to the right. The graph for the gazelle shows the gazelle initially at rest for a period of time, then speeding up to the right, and reaching a constant velocity toward the right.
(B)	This option is incorrect. The graph for the lion matches the description, but the graph for the gazelle has the gazelle immediately speeding up to the right, rather than being at rest for several seconds.
(C)	This option is incorrect. The graph for the lion shows the lion moving slowly to the right at first and then speeding up to the right. The graph for the gazelle shows the gazelle speeding up from the start. Neither graph matches the story.
(D)	This option is incorrect. The graph for the gazelle is correct, but the graph for the lion is incorrect for the reason given in option C.

Question 18

Essential Knowledge	4.B.2 The change in linear momentum of the system is given by the product of the average force on that system and the time interval during which the force is exerted.
Science Practice	5.1 The student can analyze data to identify patterns or relationships.
Learning Objective	4.B.2.2 The student is able to perform analysis on data presented as a force-time graph and predict the change in momentum of a system.
(A)	This option is incorrect. The answer is obtained by calculating the area of the two sections under the force-time graph as positive.
(B)	This option is correct. The change in speed is given by the impulse divided by the mass. The impulse can be found by calculating the area under the force-time graph in two sections. The first is a positive area of the triangle between zero and 2 s, and the second is the negative area of a rectangle between 3 and 4 s.
(C)	This option is incorrect. The answer is obtained by calculating the area under the force-time graph with the triangular section as negative and the rectangular section as positive.
(D)	This option is incorrect. The answer is obtained by calculating the area of the two sections under the force-time graph as negative.

Question 19

Essential Knowledge	4.C.2 Mechanical energy (the sum of kinetic and potential energy) is transferred into or out of a system when an external force is exerted on a system such that a component of the force is parallel to its displacement. The process through which the energy is transferred is called work.
Science Practice	6.4 The student can make claims and predictions about natural phenomena based on scientific theories and models.
Learning Objective	4.C.2.1 The student is able to make predictions about the changes in the mechanical energy of a system when a component of an external force acts parallel or antiparallel to the direction of the displacement of the center of mass.
(A)	This option is correct. The rocket's velocity will increase with a negligible decrease in mass resulting in an increase in the rocket's kinetic energy. The gravitational potential energy is proportional to $-1/r$ resulting in an increase in potential energy as r increases. The Earth-rocket system's energy resulting from the addition of the rocket's kinetic energy and the system's potential energy will also increase.
(B)	This option is incorrect. The Earth-rocket system's energy is composed of the kinetic energy of the rocket and the gravitational potential energy between them. If they both increase, the system's mechanical energy must increase as well. Work is being done on the system by the fuel so the system's energy is not constant.
(C)	This option is incorrect. As r increases, the system's gravitational potential energy must increase as it is proportional to $-1/r$. Consequently the system's mechanical energy does not decrease either.
(D)	This option is incorrect. The rocket speeds up as it accelerates away from Earth. The decrease in rocket mass is negligible therefore the kinetic energy must increase, not decrease. The change in kinetic energy should yield a change in the system's mechanical energy which does not remain constant.

Question 20

Essential Knowledge	<p>3.B.3 Restoring forces can result in oscillatory motion. When a linear restoring force is exerted on an object displaced from an equilibrium position, the object will undergo a special type of motion called simple harmonic motion. Examples should include gravitational force exerted by the Earth on a simple pendulum and mass-spring oscillator.</p> <p>5.B.3 A system with internal structure can have potential energy. Potential energy exists within a system if the objects within that system interact with conservative forces.</p>
Science Practice	<p>6.4 The student can make claims and predictions about natural phenomena based on scientific theories and models.</p> <p>7.2 The student can connect concepts in and across domain(s) to generalize or extrapolate in and/or across enduring understandings and/or big ideas.</p>
Learning Objective	<p>3.B.3.1 The student is able to predict which properties determine the motion of a simple harmonic oscillator and what the dependence of the motion is on those properties.</p> <p>5.B.3.1 The student is able to describe and make qualitative and/or quantitative predictions about everyday examples of systems with internal potential energy.</p>
(A)	This option is incorrect. The addition of block 2 does not affect the maximum kinetic energy because it is equal to the maximum spring potential energy. The period of oscillation is given by $2\pi\sqrt{\frac{m}{k}}$ therefore by increasing the mass of the oscillating object the period will increase.
(B)	This option is incorrect. The maximum kinetic energy is equal to the maximum spring potential energy which has not changed due to the addition of a block because it was placed while at maximum displacement.
(C)	This option is incorrect. The period of oscillation is given by $2\pi\sqrt{\frac{m}{k}}$. By increasing the mass of the oscillating object, the period will increase.
(D)	This option is correct. The maximum kinetic energy is equal to the maximum spring potential energy $\frac{1}{2}kx^2$ which has not changed because of the addition of a block because it was placed while at maximum displacement. The period of oscillation is given by $2\pi\sqrt{\frac{m}{k}}$ so increasing the mass of the oscillating object, the period will increase.

Question 21

Essential Knowledge	5.B.4 The internal energy of a system includes the kinetic energy of the objects that make up the system and the potential energy of the configuration of the objects that make up the system.
Science Practices	1.4 The student can use representations and models to analyze situations or solve problems qualitatively and quantitatively.
Learning Objective	5.B.4.2 The student is able to calculate changes in kinetic energy and potential energy of a system, using information from representations of that system.
(A)	This option is incorrect. There is friction between the child and slide and so the work done by friction is greater with slide B where the displacement is larger. Therefore slide B will leave the child with a smaller amount of kinetic energy than slide A.
(B)	This option is incorrect. The change in height of both slides is the same, leading to equal changes in potential energy for the system.
(C)	This option is correct. There is friction between the child and the slides, which is greater for slide B since the normal force is greater there. The displacement is also larger for slide B so it does more negative work. Therefore slide B will leave the child with a smaller amount of kinetic energy than slide A. The change in height of both slides is the same, leading to equal changes in potential energy for the system.
(D)	This option is incorrect. The change in height of both slides is the same, leading to equal changes in potential energy for the system.

Question 22

Essential Knowledge	3.B.3 Restoring forces can result in oscillatory motion. When a linear restoring force is exerted on an object displaced from an equilibrium position, the object will undergo a special type of motion called simple harmonic motion. Examples should include gravitational force exerted by the Earth on a simple pendulum and mass-spring oscillator.
Science Practices	4.2 The student can design a plan for collecting data to answer a particular scientific question.
Learning Objective	3.B.3.2 The student is able to design a plan and collect data in order to ascertain the characteristics of the motion of a system undergoing oscillatory motion caused by a restoring force.
(A)	This option is incorrect. There are no length measurements in the calculation of the spring constant because the equation for the period of oscillation is given by $2\pi\sqrt{\frac{m}{k}}$.
(B)	This option is incorrect. The motion sensor would be redundant because the period has already been measured with a stopwatch. It would also neglect to provide the mass which is a required value to calculate the spring constant.
(C)	This option is correct. The period of oscillation is given by $2\pi\sqrt{\frac{m}{k}}$ so the student would need a balance to measure the mass of the object in order to calculate the spring constant.
(D)	This option is incorrect. The photogate would be redundant because the period has already been measured with a stopwatch. It would also neglect to provide the mass which is a required value to calculate the spring constant.

Question 23

Essential Knowledge	4.C.1 The energy of a system includes its kinetic energy, potential energy, and microscopic internal energy. Examples should include gravitational potential energy, elastic potential energy, and kinetic energy.
Science Practice	2.2 The student can apply mathematical routines to quantities that describe natural phenomena.
Learning Objective	4.C.1.1 The student is able to calculate the total energy of a system and justify the mathematical routines used in the calculation of component types of energy within the system whose sum is the total energy.
(A)	This option is incorrect. This option is obtained by neglecting to square the velocity in the kinetic energy calculation.
(B)	This option is correct. Either the maximum kinetic energy $\frac{1}{2}mv^2$ or the maximum spring potential energy $\frac{1}{2}kx^2$ can be calculated using the given values and will result in an answer of approximately 4 J.
(C)	This option is incorrect. This option is obtained by adding the maximum spring potential and maximum kinetic energy which does not result in the total energy of the system.
(D)	This option is incorrect. This option is obtained by neglecting to square the amplitude in the maximum spring potential energy.

Question 24

Essential Knowledge	5.B.2 A system with internal structure can have internal energy, and changes in a system's internal structure can result in changes in internal energy. [Physics 1: includes mass-spring oscillators and simple pendulums.]
Science Practice	1.4 The student can use representations and models to analyze situations or solve problems qualitatively and quantitatively.
Learning Objective	5.B.2.1 The student is able to calculate the expected behavior of a system using the object model (i.e., by ignoring changes in internal structure) to analyze a situation. Then, when the model fails, the student can justify the use of conservation of energy principles to calculate the change in internal energy due to changes in internal structure because the object is actually a system.
(A)	This option is incorrect. Energy transferred to the spring is available to transfer back to the object in the form of kinetic energy. It would not affect the maximum potential energy of the spring or the maximum velocity of the object.
(B)	This option is incorrect. Energy transferred to the spring is available to transfer back to the object in the form of kinetic energy. It would not affect the maximum potential energy of the spring or the maximum velocity of the object.
(C)	This option is incorrect. Energy transferred to the spring is available to transfer back to the object in the form of kinetic energy. It would not affect the maximum potential energy of the spring or the maximum velocity of the object.
(D)	This option is correct. For a system's energy to be lost it must be transferred out of the system, not within the system.

Question 25

Essential Knowledge	3.A.3 A force exerted on an object is always due to the interaction of that object with another object.
Science Practice	6.4 The student can make claims and predictions about natural phenomena based on scientific theories and models.
Learning Objective	3.A.3.1 The student is able to analyze a scenario and make claims (develop arguments, justify assertions) about the forces exerted on an object by other objects for different types of forces or components of forces.
(A)	This option is incorrect. If the angle is doubled, the vertical component of the applied force is increased. The net vertical force remains zero and the gravitational force remains the same, so the normal force must compensate by decreasing.
(B)	This option is correct. If the angle is doubled, the vertical component of the applied force is increased. The net vertical force remains zero and the gravitational force remains the same, so the normal force must compensate by decreasing.
(C)	This option is incorrect. If the angle is doubled, the vertical component of the applied force is increased. The net vertical force remains zero and gravity remains the same, so the normal force cannot remain constant.
(D)	This option is incorrect. As long as the new angle is still between 0° and 90° , the new normal force must be less than the original normal force.

Question 26

Essential Knowledge	3.E.1 The change in the kinetic energy of an object depends on the force exerted on the object and on the displacement of the object during the time interval that the force is exerted.
Science Practice	6.4 The student can make claims and predictions about natural phenomena based on scientific theories and models.
Learning Objective	3.E.1.1 The student is able to make predictions about the changes in kinetic energy of an object based on considerations of the direction of the net force on the object as the object moves.
(A)	This option is incorrect. An increase in the angle θ will result in a decrease in the horizontal component of the applied force. Less work will be done on the crate resulting in a gain in kinetic energy that is less than ΔK because of the Work-Energy Theorem.
(B)	This option is correct. An increase in the angle θ will result in a decrease in the horizontal component of the applied force. Less work will be done on the crate resulting in a gain in kinetic energy that is less than ΔK because of the Work-Energy Theorem.
(C)	This option is incorrect. An increase in the angle θ will result in a decrease in the horizontal component of the applied force. Less work will be done on the crate resulting in a gain in kinetic energy that is less than ΔK because of the Work-Energy Theorem.
(D)	This option is incorrect. As long as the new angle is still between 0° and 90° , the new gain in kinetic energy must be less than ΔK .

Question 27

<p>Essential Knowledge</p>	<p>5.B.1 Classically, an object can only have kinetic energy because potential energy requires an interaction between two or more objects. 5.B.2 A system with internal structure can have internal energy, and changes in a system's internal structure can result in changes in internal energy. [Physics 1: includes mass-spring oscillators and simple pendulums.]</p>
<p>Science Practice</p>	<p>1.5 The student can re-express key elements of natural phenomena across multiple representations in the domain. 1.4 The student can use representations and models to analyze situations or solve problems qualitatively and quantitatively. 2.1 The student can justify the selection of a mathematical routine to solve problems.</p>
<p>Learning Objective</p>	<p>5.B.1.2 The student is able to translate between a representation of a single object, which can only have kinetic energy, and a system that includes the object, which may have both kinetic and potential energies. 5.B.2.1 The student is able to calculate the expected behavior of a system using the object model (i.e., by ignoring changes in internal structure) to analyze a situation. Then, when the model fails, the student can justify the use of conservation of energy principles to calculate the change in internal energy due to changes in internal structure because the object is actually a system.</p>
<p>(A)</p>	<p>This option is incorrect. The mechanical energy of the block and spring system is composed of the kinetic energy of the block and the spring potential energy. While each of those values will oscillate with time, their combination will not oscillate.</p>
<p>(B)</p>	<p>This option is incorrect. The mechanical energy of the system is not constant. Friction between the block and surface will result in the system losing mechanical energy.</p>
<p>(C)</p>	<p>This option is incorrect. The mechanical energy of the block is composed of the kinetic energy of the block only. The kinetic energy is a function of v^2 and will oscillate.</p>
<p>(D)</p>	<p>This option is correct. The mechanical energy of the block is composed of the kinetic energy of the block only. The kinetic energy is a function of v^2 and will oscillate. The mechanical energy of the block and spring system is composed of the kinetic energy of the block and spring potential energy. While each of those values will oscillate with time, their combination will not oscillate. However, friction between the block and surface will result in the system losing mechanical energy, therefore both the energy of the block and the energy of the system will decrease.</p>

Question 28

<p>Essential Knowledge</p>	<p>3.A.1 An observer in a particular reference frame can describe the motion of an object using such quantities as position, displacement, distance, velocity, speed, and acceleration.</p> <p>6.B For a periodic wave, the period is the repeat time of the wave. The frequency is the number of repetitions of the wave per unit time.</p>
<p>Science Practice</p>	<p>1.4 The student can use representations and models to analyze situations or solve problems qualitatively and quantitatively.</p> <p>1.5 The student can re-express key elements of natural phenomena across multiple representations in the domain.</p> <p>2.2 The student can apply mathematical routines to quantities that describe natural phenomena.</p>
<p>Learning Objective</p>	<p>3.A.1.1 The student is able to express the motion of an object using narrative, mathematical, and graphical representations.</p> <p>6.B.1.1 The student is able to use a graphical representation of a periodic mechanical wave (position versus time) to determine the period and frequency of the wave and describe how a change in the frequency would modify features of the representation.</p>
<p>(A)</p>	<p>This option is incorrect. The point on the string is moving up and down; the average speed cannot be zero. This option is obtained by finding the average velocity for each oscillation.</p>
<p>(B)</p>	<p>This option is incorrect. This answer is obtained by finding the distance traveled by the point without dividing by time.</p>
<p>(C)</p>	<p>This option is incorrect. This answer gives the average speed of the point using the graph provided without doubling the frequency.</p>
<p>(D)</p>	<p>This option is correct. During one full oscillation, the point on the string will travel a distance of 4 times the amplitude, or 2.4 m which is not affected by doubling the frequency. The period will be cut in half becoming 0.25 s. Calculating the average speed as distance divided by time results in an average speed of 9.6 m/s.</p>

Question 29

Essential Knowledge	6.A.2 For propagation, mechanical waves require a medium, while electromagnetic waves do not require a physical medium. Examples should include light traveling through a vacuum and sound not traveling through a vacuum.
Science Practice	6.4 The student can make claims and predictions about natural phenomena based on scientific theories and models. 7.2 The student can connect concepts in and across domain(s) to generalize or extrapolate in and/or across enduring understandings and/or big idea.
Learning Objective	6.A.2.1 The student is able to describe sound in terms of transfer of energy and momentum in a medium and relate the concepts to everyday examples.
(A)	This option is incorrect. Sound travels at a speed based on the conditions of the medium it is traveling through. Increasing the volume increases the amplitude of the sound wave, not the speed.
(B)	This option is incorrect. The material and geometry of the walls aren't changing, so the amount of waves reflected will remain unchanged.
(C)	This option is correct. Increasing the volume of sound increases the amplitude of the sound wave meaning that the air molecules will undergo a greater displacement from equilibrium.
(D)	This option is incorrect. Increasing the volume of sound increases the amplitude of the wave and does not affect the average spacing between the molecules.

Question 30

Essential Knowledge	6.D.4 The possible wavelengths of a standing wave are determined by the size of the region to which it is confined.
Science Practice	1.5 The student can re-express key elements of natural phenomena across multiple representations in the domain. 6.1 The student can justify claims with evidence.
Learning Objective	6.D.4.1 The student is able to challenge with evidence the claim that the wavelengths of standing waves are determined by the frequency of the source regardless of the size of the region.
(A)	This option is incorrect. The speed of a wave down the string will only be dependent on the tension in the string and the linear density of the string. If both of those are identical for the two strings, then the speed of the waves will be the same down each string.
(B)	This option is incorrect. It is possible to set a frequency that results in a standing wave on one string and a standing wave of a different harmonic on the second string if the lengths of the two strings have an appropriate ratio.
(C)	This option is incorrect. The amplitude of the wave will not factor into the ability or inability to create a standing wave, it will only impact the height of the resulting wave.
(D)	This option is correct. In order to create a standing wave on a string, the length of the string must be of a proper length so that it is $n/2$ times the wavelength of the wave created by the oscillator, where n is a positive integer.

Question 31

Essential Knowledge	5.B.5 Energy can be transferred by an external force exerted on an object or system that moves the object or system through a distance. This process is called doing work on a system. The amount of energy transferred by this mechanical process is called work. Energy transfer in mechanical or electrical systems may occur at different rates. Power is defined as the rate of energy transfer into, out of, or within a system.
Science Practice	2.2 The student can apply mathematical routines to quantities that describe natural phenomena.
Learning Objective	5.B.5.3 The student is able to predict and calculate from graphical data the energy transfer to or work done on an object or system from information about a force exerted on the object or system through a distance.
(A)	This option is incorrect. This option is obtained by neglecting the $1/2$ in the calculation of kinetic energy.
(B)	This option is correct. The Work-Energy Theorem is used by calculating the area under the line and equating it to the change in kinetic energy.
(C)	This option is incorrect. This option is obtained by incorrectly equating the area under the line to impulse and change in momentum.
(D)	This option is incorrect. This option is obtained by calculating the area under the line as the force times the distance without accounting for the area being a triangle.

Question 32

Essential Knowledge	5.D.1 In a collision between objects, linear momentum is conserved. In an elastic collision, kinetic energy is the same before and after.
Science Practice	2.2 The student can apply mathematical routines to quantities that describe natural phenomena.
Learning Objective	5.D.1.5 The student is able to classify a given collision situation as elastic or inelastic, justify the selection of conservation of linear momentum and restoration of kinetic energy as the appropriate principles for analyzing an elastic collision, solve for missing variables, and calculate their values.
(A)	This option is incorrect. Cart X will not continue on with the same velocity after colliding with cart Y. This would violate the conservation of momentum. When cart Y begins to move it gains momentum and so cart X must lose momentum.
(B)	This option is incorrect. Both carts have the same mass and velocity after sticking together, so they have the same momentum requiring them to each have half the initial momentum of Cart X. The only way for Cart X to have more than half the momentum is if Cart X is more massive than Cart Y, which is not the case.
(C)	This option is correct. Using conservation of momentum, the final velocity of cart X is found to be 1 m/s. Cart Y will gain half of the original momentum and cart X will lose half of its original momentum resulting in half the original velocity for cart X.
(D)	This option is incorrect. Colliding with cart Y will not cause cart X to come to a complete stop. This would be the case if the collision was elastic, but the carts stick together after colliding as the result of a completely inelastic collision.

Question 33

Essential Knowledge	5.D.3 The velocity of the center of mass of the system cannot be changed by an interaction within the system. [Physics 1: includes no calculations of centers of mass; the equation is not provided until Physics 2. However, without doing calculations, Physics 1 students are expected to be able to locate the center of mass of highly symmetric mass distributions, such as a uniform rod or cube of uniform density, or two spheres of equal mass.]
Science Practice	6.4 The student can make claims and predictions about natural phenomena based on scientific theories and models.
Learning Objective	5.D.3.1 The student is able to predict the velocity of the center of mass of a system when there is no interaction outside of the system but there is an interaction within the system (i.e., the student simply recognizes that interactions within a system do not affect the center of mass motion of the system and is able to determine that there is no external forces.
(A)	This option is incorrect. Because the spaceship is moving with speed v_f and the pod has a lower speed, the speed of the center of mass of the system must be somewhere between v_p and v_f .
(B)	This option is incorrect. There are no external forces acting on the system during the separation, so there is no impulse on the system and no change in the velocity of the center of mass. Because the speed of the center of mass was v before the separation, it cannot be greater than v after separation.
(C)	This option is incorrect. There are no external forces acting on the system during the separation, so there is no impulse on the system and no change in the velocity of the center of mass. Because the speed of the center of mass was v before the separation, it cannot be less than v after separation.
(D)	This option is correct. Because there are no external forces acting on the system consisting of both the pod and the spaceship, there is no impulse on this system and therefore no change in the velocity of its center of mass. Because the center of mass was moving with speed v before the separation, it will continue to move at speed v.

Question 34

Essential Knowledge	5.E.1 If the net external torque exerted on the system is zero, the angular momentum of the system does not change.
Science Practice	6.4 The student can make claims and predictions about natural phenomena based on scientific theories and models.
Learning Objective	5.E.1.1 The student is able to make qualitative predictions about the angular momentum of a system for a situation in which there is no net external torque.
(A)	This option is incorrect. This action will decrease the angular momentum of the child and increase the angular momentum of the platform. However, there are no external forces on the child-platform system, so the angular momentum of the system does not change.
(B)	This option is incorrect. This action will increase the angular momentum of the child and decrease the angular momentum of the platform. However, there are no external forces on the child-platform system, so the angular momentum of the system does not change.
(C)	This option is incorrect. If the child moves along the circle, the interaction forces between the child and the platform will act to increase the angular momentum of the platform and decrease the angular momentum of the child. However, there are no external forces on the child-platform system, so the angular momentum of the system does not change.
(D)	This option is correct. All of the actions described result in interaction forces between the child and the platform, but do not result in external torques on the child-platform system. Because there are no external torques on the child-platform system, the angular momentum of the system does not change.

Question 35

<p>Essential Knowledge</p>	<p>3.A.1 An observer in a particular reference frame can describe the motion of an object using such quantities as position, displacement, distance, velocity, speed, and acceleration. 4.A The linear motion of a system can be described by the displacement, velocity, and acceleration of its center of mass.</p>
<p>Science Practice</p>	<p>1.4 The student can use representations and models to analyze situations or solve problems qualitatively and quantitatively. 1.5 The student can re-express key elements of natural phenomena across multiple representations in the domain. 2.3 The student can estimate numerically quantities that describe natural phenomena. 6.4 The student can make claims and predictions about natural phenomena based on scientific theories and models.</p>
<p>Learning Objective</p>	<p>3.A.1.1 The student is able to express the motion of an object using narrative, mathematical, and graphical representations. 4.A.1.1 The student is able to use representations of the center of mass of an isolated two-object system to analyze the motion of the system qualitatively and semi-quantitatively.</p>
<p>(A)</p>	<p>This option is incorrect. Because the velocity of the center of mass of the spheres is zero in the reference frame of the train (see explanation for option B), it cannot also be zero in the reference frame of the person at rest alongside the train.</p>
<p>(B)</p>	<p>This option is correct. The spheres are identical and are traveling at the same speed in opposite directions in the reference frame of the train, so the center of mass of the spheres has zero velocity in that reference frame. Because the train has velocity v_t east in the reference frame of the person alongside the train, and the center of mass of the spheres is at rest in the reference frame of the train, the center of mass will also have a velocity v_t east in the reference frame of the person alongside the train.</p>
<p>(C)</p>	<p>This option is incorrect. Because the train has speed v_t with respect to the person alongside the train, the velocity of the center of mass as measured in the two reference frames must differ by v_t.</p>
<p>(D)</p>	<p>This option is incorrect. In the reference frame of the person alongside the train one sphere has velocity $v_p + v_t$ east and one sphere has velocity $v_t - v_p$ east. For nonzero v_t the velocity of the center of mass in this reference frame cannot be zero.</p>

Question 36

<p>Essential Knowledge</p>	<p>5.E.2 The angular momentum of a system is determined by the locations and velocities of the objects that make up the system. The rotational inertia of an object or system depends upon the distribution of mass within the object or system. Changes in the radius of a system or in the distribution of mass within the system result in changes in the system's rotational inertia, and hence in its angular velocity and linear speed for a given angular momentum. Examples should include elliptical orbits in an Earth-satellite system. Mathematical expressions for the moments of inertia will be provided where needed. Students will not be expected to know the parallel axis theorem.</p>
<p>Science Practice</p>	<p>2.2 The student can apply mathematical routines to quantities that describe natural phenomena.</p>
<p>Learning Objective</p>	<p>5.E.2.1 The student is able to describe or calculate the angular momentum and rotational inertia of a system in terms of the locations and velocities of objects that make up the system. Students are expected to do qualitative reasoning with compound objects. Students are expected to do calculations with a fixed set of extended objects and point masses.</p>
<p>(A)</p>	<p>This option is incorrect. The rotational inertia of an object depends on the distribution of mass within the object. When the panels unfold some of the mass of the satellite moves away from the axis of rotation and the moment of inertia changes, so a cannot equal 1. As discussed in option B, this also causes a change in angular velocity, so b cannot equal 1.</p>
<p>(B)</p>	<p>This option is correct. When the panels unfold, some of the mass of the satellite is moving away from the axis of rotation, causing the moment of inertia of the satellite to increase, so $a > 1$. Because there is no external torque acting on the satellite, angular momentum of the satellite must stay the same at $I_0\omega_0 = I_f\omega_f$. When the moment of inertia increases the angular velocity must decrease, so $b < 1$.</p>
<p>(C)</p>	<p>This option is incorrect. Because the moment of inertia of the panels increases (as discussed in option B) the constant a is greater than one. Because there is no external torque on the satellite as the panels unfold there can be no change in the angular momentum, and an increase in moment of inertia must coincide with a corresponding decrease in angular velocity, so b cannot be equal to 1.</p>
<p>(D)</p>	<p>This option is incorrect. If both a and b are less than one, then as the panels unfold there is decrease in both moment of inertia and angular velocity of the satellite, and the angular momentum of the satellite would decrease. However, in the absence of a net external torque the angular momentum of the satellite must remain the same.</p>

Question 37

Essential Knowledge	5.B.9 Kirchhoff's loop rule describes conservation of energy in electrical circuits. The application of Kirchhoff's laws to circuits is introduced in Physics 1 and further developed in Physics 2 in the context of more complex circuits, including those with capacitors.
Science Practice	2.2 The student can apply mathematical routines to quantities that describe natural phenomena.
Learning Objective	5.B.9.3 The student is able to apply conservation of energy (Kirchhoff's loop rule) in calculations involving the total electric potential difference for complete circuit loops with only a single battery and resistors in series and/or in, at most, one parallel branch.
(A)	This option is incorrect. When R_3 is removed, the current in R_2 changes, therefore the potential difference across R_2 must change as well.
(B)	This option is incorrect. When R_3 is removed, the resistance of the circuit increases, and the current in the battery (and in R_1) decreases. Because the current in R_1 decreases, the voltage across it does as well, and (using Kirchhoff's loop rule) the voltage across R_2 increases.
(C)	This option is correct. With R_3 in place, the current in R_1 splits evenly at the junction above R_2 and R_3, because R_2 and R_3 have the same resistance, and the current in R_2 will be one-half of the current in R_1. Because R_1 and R_2 have the same resistance, the voltage across R_2 will be one-half of the voltage across R_1. With R_3 removed, R_1 and R_2 are in series and will have the same current, and because they have the same resistance they will also have the same voltage. From Kirchhoff's loop rule, the sum of the voltages across R_1 and R_2 must equal the battery voltage, so with R_3 in place the voltage across R_2 is 1 V (and the voltage across R_1 is double that, 2 V), and with R_3 removed, the voltage across R_2 is 1.5 V, the same as R_1. The potential difference across R_2 increases 0.5 V from 1 V to 1.5 V.
(D)	This option is incorrect. The potential difference across R_3 increases by 0.5 V as described in the explanation for option B.

Question 38

Essential Knowledge	6.D.1 Two or more wave pulses can interact in such a way as to produce amplitude variations in the resultant wave. When two pulses cross, they travel through each other; they do not bounce off each other. Where the pulses overlap, the resulting displacement can be determined by adding the displacements of the two pulses. This is called superposition.
Science Practice	1.1 The student can create representations and models of natural or man-made phenomena and systems in the domain. 1.4 The student can use representations and models to analyze situations or solve problems qualitatively and quantitatively.
Learning Objective	6.D.1.1 The student is able to use representations of individual pulses and construct representations to model the interaction of two wave pulses to analyze the superposition of two pulses.
(A)	This option is incorrect. When the pulses overlap the instantaneous pulse shape is determined by adding the displacements of the two pulses, and the displacement everywhere but at the pulse edges will be smaller than the square pulse displacement.
(B)	This option is incorrect. Because the pulses are on opposite sides of the line, when they align the triangular pulse acts to reduce the displacement of the square pulse.
(C)	This option is correct. When the centers of the pulses align, the resulting pulse shape is the superposition of the pulse displacements. At the center, the amplitudes exactly cancel giving zero displacement. At other locations the displacement of the triangle pulse acts to reduce the displacement of the square pulse creating a smaller displacement.
(D)	This option is incorrect. When the centers of the pulses align, the displacement of the center of the pulse will be zero because the square and triangle pulses have equal displacement and are on opposite sides of the line. Because the displacement of the triangular pulse is zero at its edges the displacement of the superposition of the pulses will be the same as the displacement of the square pulse at the edges.

Question 39

Essential Knowledge	5.B.3 A system with internal structure can have potential energy. Potential energy exists within a system if the objects within that system interact with conservative forces.
Science Practice	1.4 The student can use representations and models to analyze situations or solve problems qualitatively and quantitatively. 2.2 The student can apply mathematical routines to quantities that describe natural phenomena.
Learning Objective	5.B.3.2 The student is able to make quantitative calculations of the internal potential energy of a system from a description or diagram of that system.
(A)	This option is correct. The gravitational potential energy of the system will decrease by $mg\Delta h$, or approximately $(40\text{ N})(0.1\text{ m}) = 4\text{ J}$. The potential energy of the spring will increase by one-half times k times $(\Delta h)^2$, or $(0.5)(500\text{ N/m})(0.1\text{ m})^2 = 2.5\text{ J}$. There is no change in kinetic energy for the system, because it starts and ends at rest. The overall energy of the block-spring-Earth system therefore decreases by 1.5 J.
(B)	This option is incorrect. The spring potential energy increases by 2.5 J (see explanation in option A), but there is also a change in the gravitational potential energy of the system.
(C)	This option is incorrect. The gravitational potential energy decreases by 4.0 J (see explanation in option A), but there is also a change in the spring potential energy.
(D)	This option is incorrect. The kinetic energy of the system does not change, because the components of the system start and end at rest. However, the potential energy, and therefore the overall energy, decreases.

Question 40

Essential Knowledge	3.A.4 If one object exerts a force on a second object, the second object always exerts a force of equal magnitude on the first object in the opposite direction.
Science Practice	1.4 The student can use representations and models to analyze situations or solve problems qualitatively and quantitatively.
Learning Objective	3.A.4.1 The student is able to construct explanations of physical situations involving the interaction of bodies using Newton's third law and the representation of action-reaction pairs of force.
(A)	This option is correct. For each stack of blocks, the forces being compared form a Newton's third law pair (an action-reaction pair) and are therefore equal in magnitude in each case.
(B)	This option is incorrect. The forces being compared form a Newton's third law pair for each stack of blocks, and must always have the same magnitude.
(C)	This option is incorrect. The forces being compared form a Newton's third law pair for each stack of blocks, and must always have the same magnitude. These forces are normal forces, not gravitational forces.
(D)	This option is incorrect. The forces being compared form a Newton's third law pair for each stack of blocks, and Newton's third law is valid whether the objects in question are accelerating or not.

Question 41

Essential Knowledge	3.B.2 Free-body diagrams are useful tools for visualizing forces being exerted on a single object and writing the equations that represent a physical situation.
Science Practice	1.4 The student can use representations and models to analyze situations or solve problems qualitatively and quantitatively.
Learning Objective	3.B.2.1 The student is able to create and use free-body diagrams to analyze physical situations to solve problems with motion qualitatively and quantitatively.
(A)	This option is incorrect. There is a downward normal force exerted on the bottom box by the top box.
(B)	This option is incorrect. There is a downward gravitational force on the bottom box by the Earth.
(C)	This option is correct. The gravitational force on the blocks must be the same, because they have the same mass. Both boxes are moving upward with constant velocity, so the net force on each box must be zero. The only forces acting on the top box are the upward normal force by the bottom box and the gravitational force, so the normal force must have the same magnitude as the gravitational force. The normal force downward on the bottom box must be equal in magnitude to the upward normal force on the top box (they form a Newton's third law pair). So the gravitational force on the bottom box by the Earth must have the same magnitude as the normal force on the bottom box by the top box (both of these point downward). Because the net force on the bottom box is zero the two downward forces must balance the upward force by the floor.
(D)	This option is incorrect. The force exerted by the top box on the bottom box is a downward normal force.

Question 42

Essential Knowledge	3.B.1 If an object of interest interacts with several other objects, the net force is the vector sum of the individual forces.
Science Practice	2.2 The student can apply mathematical routines to quantities that describe natural phenomena.
Learning Objective	3.B.1.3 The student is able to re-express a free-body diagram representation into a mathematical representation and solve the mathematical representation for the acceleration of the object.
(A)	This option is incorrect. The upward force exerted on the top box by the bottom box must be greater than the downward gravitational force on the top box (Mg) because the top box is accelerating upward.
(B)	This option is incorrect. In addition to the upward force exerted on the top box by the bottom box there is a downward gravitational force on the top box. In order for the net force on the top box to be equal to Ma , the upward force by the bottom box must be greater than Ma .
(C)	This option is incorrect. If the top box were moving upward with no acceleration, there would be no net force acting on it, so the upward force exerted on the top box by the bottom box would be equal to the downward gravitational force Mg . The upward force must be greater than this to obtain an upward acceleration, so a and g must add together as described in the explanation for option D.
(D)	This option is correct. The forces acting on the top box are the downward gravitational force by the Earth (Mg) and an upward normal force on the top box by the bottom box F_N. Because the top box is accelerating upward, there must be a net upward force on it equal to Ma. From Newton's second law we have $F_N - Mg = Ma$, so $F_N = M(a + g)$.

Question 43

Essential Knowledge	1.B.3 The smallest observed unit of charge that can be isolated is the electron charge, also known as the elementary charge.
Science Practice	6.1 The student can justify claims with evidence.
Learning Objective	1.B.3.1 The student is able to challenge the claim that an electric charge smaller than the elementary charge has been isolated.
(A)	This option is incorrect. A particle emitted from a collision will have a charge that is an integer multiple of the elementary charge $1.6 \times 10^{-19} \text{ C}$. Five times the elementary charge is $8.0 \times 10^{-19} \text{ C}$, and six times the elementary charge is $9.6 \times 10^{-19} \text{ C}$. The analysis gives a value for a charge from $8.7 \times 10^{-19} \text{ C}$ to $8.9 \times 10^{-19} \text{ C}$, which is not an integer multiple of the elementary charge.
(B)	This option is incorrect. The relative size is not the crucial consideration, as long as the value obtained is an integer multiple of the elementary charge.
(C)	This option is correct. A particle emitted from a collision will have a charge that is an integer multiple of the elementary charge $1.6 \times 10^{-19} \text{ C}$. Five times the elementary charge is $8.0 \times 10^{-19} \text{ C}$, and six times the elementary charge is $9.6 \times 10^{-19} \text{ C}$. The analysis gives a range of values between $8.7 \times 10^{-19} \text{ C}$ and $8.9 \times 10^{-19} \text{ C}$, which is not an integer multiple of the elementary charge.
(D)	This option is incorrect. There are many useful experiments with an uncertainty greater than 1% of the value to be determined.

Question 44

<p>Essential Knowledge</p>	<p>5.C.3 Kirchhoff's junction rule describes the conservation of electric charge in electrical circuits. Because charge is conserved, current must be conserved at each junction in the circuit. Examples should include circuits that combine resistors in series and parallel. [Physics 1: covers circuits with resistors in series, with at most one parallel branch, one battery only.]</p>
<p>Science Practice</p>	<p>1.4 The student can use representations and models to analyze situations or solve problems qualitatively and quantitatively. 2.2 The student can apply mathematical routines to quantities that describe natural phenomena.</p>
<p>Learning Objective</p>	<p>5.C.3.3 The student is able to use a description or schematic diagram of an electrical circuit to calculate unknown values of current in various segments or branches of the circuit.</p>
<p>(A)</p>	<p>This option is incorrect. It is the value of the current in the $6\ \Omega$ resistor. The battery current is 4 A, as described in the explanation for option B. When the current splits at the junction after the $1\ \Omega$ resistor, more than half will be in the branch with the $3\ \Omega$ resistor because that is the branch with the least resistance, so the current in this branch must be greater than 2 A.</p>
<p>(B)</p>	<p>This option is correct. The resistance of the parallel combination of $3\ \Omega$ and $6\ \Omega$ is $2\ \Omega$ (that is $(1/3\ \Omega + 1/6\ \Omega)^{-1}$). This parallel combination is in series with the $1\ \Omega$ resistor, giving an overall resistance of $3\ \Omega$ for the circuit. The current in the battery is therefore $12\ \text{V}/3\ \Omega$ or 4 A. The 4 A battery current splits at the junction after the $1\ \Omega$ resistor. Twice as much current will be in the $3\ \Omega$ resistor as will be in the $6\ \Omega$ resistor, because there is half as much resistance and both resistors must have the same voltage drop across them. Of the 4 A battery current, 1.33 A will be in the $6\ \Omega$ branch and 2.66 A will be in the $3\ \Omega$ branch.</p>
<p>(C)</p>	<p>This option is incorrect. The battery current is 4 A, as described in the explanation for option B. This current splits at the junction after the $1\ \Omega$ resistor, with two-thirds of the current (or 2.66 A) going to the branch with the $3\ \Omega$ resistor.</p>
<p>(D)</p>	<p>This option is incorrect. The battery current is 4 A, as described in the explanation for option B. This current splits at the junction after the $1\ \Omega$ resistor, and the current in the $3\ \Omega$ resistor is therefore less than 4 A.</p>

Question 45

Essential Knowledge	6.D.3 Standing waves are the result of the addition of incident and reflected waves that are confined to a region and have nodes and antinodes. Examples should include waves on a fixed length of string, and sound waves in both closed and open tubes.
Science Practice	3.2 The student can justify the selection of a mathematical routine to solve problems.
Learning Objective	6.D.3.1 The student is able to refine a scientific question related to standing waves and design a detailed plan for the experiment that can be conducted to examine the phenomenon qualitatively or quantitatively.
(A)	This option is correct. Temperature is an uncontrolled variable in the original experiment, and the modification described helps both to learn whether the frequencies change when temperature changes, and to see whether frequencies stay the same when temperature is constant.
(B)	This option is incorrect. The length of the tube was not varied in the original experiment, and yet the frequencies changed. The tube length did not cause the variation.
(C)	This option is incorrect. With a wider range of frequencies and equivalent conditions, the same variation of results would be expected for frequencies that were in the original experiment.
(D)	This option is incorrect. The same variation of results would be expected with a longer experiment.

Question 46

Essential Knowledge	4.D.1 Torque, angular velocity, angular acceleration, and angular momentum are vectors and can be characterized as positive or negative depending upon whether they give rise to or correspond to counterclockwise or clockwise rotation with respect to an axis.
Science Practice	4.1 The student can justify the selection of the kind of data needed to answer a particular scientific question.
Learning Objective	4.D.1.2 The student is able to plan data collection strategies designed to establish that torque, angular velocity, angular acceleration, and angular momentum can be predicted accurately when the variables are treated as being clockwise or counterclockwise with respect to a well-defined axis of rotation, and refine the research question based on the examination of data.
(A)	This option is incorrect. To make the plank balance horizontally, the torques exerted on the plank by the blocks on each side of the pivot ($\tau = R_{\perp}F$) must be equal. Because the pivot is placed at the center of the uniform plank, the gravitational force on the plank is equal on both sides of the pivot (at the center of mass of the plank), therefore the weight of the plank exerts no net torque.
(B)	This option is correct. To make the plank balance horizontally, the torques exerted on the plank by the blocks on each side of the pivot ($\tau = R_{\perp}F$) must be equal. To determine the torque exerted by each block, the mass of each block or the relative masses of the two blocks must be known to calculate torques and relative placements of the blocks.
(C)	This option is incorrect. To make the plank balance horizontally, the torques exerted on the plank by the blocks on each side of the pivot ($\tau = R_{\perp}F$) must be equal. As long as the plank is centered on the pivot so that the weight of the plank exerts no torque, only the distances of the blocks from the pivot are needed, not the length of the plank.
(D)	This option is correct. To make the plank balance horizontally, the torques exerted on the plank by the blocks on each side of the pivot ($\tau = R_{\perp}F$) must be equal. To determine the torque exerted by each block, the distance of each block from the pivot (R) must be known.

Question 47

<p>Essential Knowledge</p>	<p>3.B.1 If an object of interest interacts with several other objects, the net force is the vector sum of the individual forces.</p>
<p>Science Practice</p>	<p>1.5 The student can re-express key elements of natural phenomena across multiple representations in the domain. 2.2 The student can apply mathematical routines to quantities that describe natural phenomena.</p>
<p>Learning Objective</p>	<p>3.B.1.3 The student is able to re-express a free-body diagram representation into a mathematical representation and solve the mathematical representation for the acceleration of the object.</p>
<p>(A)</p>	<p>This option is incorrect. The forces exerted on the block are the pushing force F in the direction shown, the normal force perpendicular to the block toward the left, the weight of the block straight downward, and the friction force straight upward or downward between the block and wall, depending on the magnitude of F. For the block to be in equilibrium in the vertical direction, $F_g - F \sin \theta \pm F_f = 0$. This answer choice incorrectly omits the friction force.</p>
<p>(B)</p>	<p>This option is correct. The forces exerted on the block are the pushing force F in the direction shown, the normal force perpendicular to the block toward the left, the weight of the block straight downward, and the friction force straight upward or downward between the block and wall, depending on the magnitude of F. For the block to be in equilibrium in the horizontal direction, $F \cos \theta = F_N$.</p>
<p>(C)</p>	<p>This option is correct. The forces exerted on the block are the pushing force F in the direction shown, the normal force perpendicular to the block toward the left, the weight of the block straight downward, and the friction force straight upward or downward between the block and wall. For the block to be in equilibrium in the vertical direction, $F \sin \theta = F_g \pm F_f$.</p>
<p>(D)</p>	<p>This option is incorrect. The forces exerted on the block are the pushing force F in the direction shown, the normal force perpendicular to the block toward the left, the weight of the block straight downward, and the friction force straight upward between the block and wall. This answer choice incorrectly mixes forces in the horizontal and vertical directions and does not use components of F. The situation is in two dimensions, so the forces must be considered separately in each dimension.</p>

Question 48

Essential Knowledge	1.C.1 Inertial mass is the property of an object or a system that determines how its motion changes when it interacts with other objects or systems. 1.C.3 Objects and systems have properties of inertial mass and gravitational mass that are experimentally verified to be the same and that satisfy conservation principles.
Science Practice	4.2 The student can design a plan for collecting data to answer a particular scientific question.
Learning Objective	1.C.1.1 The student is able to design an experiment for collecting data to determine the relationship between the net force exerted on an object, its inertial mass, and its acceleration. 1.C.3.1 The student is able to design a plan for collecting data to measure gravitational mass and to measure inertial mass, and to distinguish between the two experiments.
(A)	This option is incorrect. The process of hanging the object vertically on a spring scale determines only the weight of the object or gravitational mass but does not compare to inertial mass. The procedure relies upon the gravitational field.
(B)	This option is incorrect. The process described here compares the effect of gravity on both sides of a pan balance, so only gravitational mass is considered. There is no comparison to inertial mass. This procedure relies upon the gravitational field.
(C)	This option is correct. For the spring oscillating horizontally, measuring the period (with a known spring constant) allows students to calculate the inertial mass of the object attached to the spring. This can now be compared to the gravitational mass determined previously. This procedure would work without a gravitational field.
(D)	This option is correct. Pulling the object across a horizontal surface allows application of Newton’s second law in the horizontal direction, which determines the inertial mass (knowing the force and acceleration). This procedure would work without a gravitational field.

Question 49

Essential Knowledge	6.A.1 Waves can propagate via different oscillation modes such as transverse and longitudinal.
Science Practice	1.2 The student can describe representations and models of natural or man-made phenomena and systems in the domain.
Learning Objective	6.A.1.2 The student is able to describe representations of transverse and longitudinal waves.
(A)	This option is correct. At the instant shown, the particles in the medium have been displaced from their equilibrium positions along the direction of travel of the wave, so the wave is a longitudinal wave.
(B)	This option is correct. The wave pattern repeats itself from any point along the wave to a second point a distance a away. Distance a is therefore the wavelength of the wave.
(C)	This option is incorrect. The frequency of the wave is the number of times a single particle repeats its periodic motion per unit time.
(D)	This option is incorrect. The amplitude of the wave is the maximum displacement of a single particle from its rest position.

Question 50

Essential Knowledge	6.D.2 Two or more traveling waves can interact in such a way as to produce amplitude variations in the resultant wave.
Science Practice	5.1 The student can analyze data to identify patterns or relationships.
Learning Objective	6.D.2.1 The student is able to analyze data or observations or evaluate evidence of the interaction of two or more traveling waves in one or two dimensions (i.e., circular wave fronts) to evaluate the variations in resultant amplitudes.
(A)	This option is correct. The pattern shown is a beat pattern created by the superposition of two waves of slightly different frequencies. The amplitude of the wave varies as a function of time because at the position of the sensor the two waves sometimes constructively interfere and sometimes destructively interfere.
(B)	This option is correct. When the two waves destructively interfere, the amplitude of the superposition of the waves is at a minimum. If the two traveling waves had the same amplitude, the destructive interference would give a resultant zero amplitude wave at the minimum. The wave on the monitor has a nonzero minimum.
(C)	This option is incorrect. The direction of motion of the individual waves cannot be determined from either the signal measured at a single location or an instantaneous view of the signal.
(D)	This option is incorrect. Both traveling waves are traveling to the sensor through the same layer of rock, and because they are in the same medium, they have the same speed.

Answers to Multiple-Choice Questions

1 – D	14 – D	27 – D	40 – A
2 – A	15 – C	28 – D	41 – C
3 – D	16 – A	29 – C	42 – D
4 – B	17 – A	30 – D	43 – C
5 – B	18 – B	31 – B	44 – B
6 – C	19 – A	32 – C	45 – A
7 – C	20 – D	33 – D	46 – B, D
8 – C	21 – C	34 – D	47 – B, C
9 – A	22 – C	35 – B	48 – C, D
10 – D	23 – B	36 – B	49 – A, B
11 – B	24 – D	37 – C	50 – A, B
12 – C	25 – B	38 – C	
13 – C	26 – B	39 – A	

Free-Response Section

Section II is the free-response part of the exam. This section contains five free-response questions, and the student will have a total of 90 minutes to complete them all.

Information for Free-Response Question 1

Timing	The student should spend approximately 10–13 minutes on this question.
Essential Knowledge/ Big Ideas	<p>3.A.1 An observer in a particular reference frame can describe the motion of an object using such quantities as position, displacement, distance, velocity, speed, and acceleration.</p> <p>4.A.3 Forces that systems exert on each other are because of interactions between objects in the systems. If the interacting objects are parts of the same system, there will be no change in the center-of-mass velocity of that system.</p> <p>4.B.1 The change in linear momentum for a constant-mass system is the product of the mass of the system and the change in velocity of the center of mass.</p> <p>4.B.2 The change in linear momentum of the system is given by the product of the average force on that system and the time interval during which the force is exerted.</p>
Science Practice	<p>2.2 The student can apply mathematical routines to quantities that describe natural phenomena.</p> <p>5.1 The student can analyze data to identify patterns or relationships.</p>
Learning Objective	<p>3.A.1.3 The student is able to analyze experimental data describing the motion of an object and is able to express the results of the analysis using narrative, mathematical, and graphical representations.</p> <p>4.A.3.1 The student is able to apply Newton’s second law to systems to calculate the change in the center-of-mass velocity when an external force is exerted on the system.</p> <p>4.B.1.1 The student is able to calculate the change in linear momentum of a two-object system with constant mass in linear motion from a representation of the system (data, graphs, etc.).</p> <p>4.B.2.1 The student is able to apply mathematical routines to calculate the change in momentum of a system by analyzing the average force exerted over a certain time on the system.</p>
Characteristics of a STRONG Response	<p>Part (a) The student is able to recognize and state that the measurements were NOT started at the time of release because the carts have non-zero momentum at $t = 0$.</p> <p>Part (b) The student is able to</p> <ul style="list-style-type: none"> • Use the graph to calculate the change in momentum for each cart • Recognize that the “external force” is the sum of the two forces on the carts. <p>Part (c) The student correctly states that there is no difference and recognizes that as long as the net mass of the system remains unchanged, the net effect on the system remains unchanged as well.</p>

<p>Characteristics of a GOOD Response</p>	<p>Part (a) The student implies the reason the measurements were not started at the time of release, instead of making an explicit statement.</p> <p>Part (b) The student is able to</p> <ul style="list-style-type: none"> • Use the graph to calculate the change in momentum for each cart • Recognize that the “external force” is the sum of the two forces on the carts but fails to account that the forces are in opposite directions and/or performs a miscalculation. <p>Part (c) The student is able to recognize that the answers would not be different, but has difficulty explaining why.</p>
<p>Characteristics of a WEAK Response</p>	<p>Part (a) The student states that the measurements were started at the same time.</p> <p>OR</p> <p>The student has difficulty in stating a correct reason why the measurements were not started upon release.</p> <p>Part (b) The student is able to calculate only the force on a single cart.</p> <p>Part (c) The student incorrectly states that the answers would be different.</p> <p>OR</p> <p>The student states the answers would not be different with no attempt at a justification.</p>

Scoring Guidelines for Free-Response Question 1

Question 1

7 points total	Distribution of points
(a) 1 point	
For a correct, justified response about the state of motion at time $t = 0$ For example: No. The carts have a non-zero momentum at $t = 0$, so this cannot be the instant they were released.	1 point
(b) 4 points	
For using the relationship between force and momentum, or Newton's second law and the definitions of acceleration and momentum $F = \Delta p / \Delta t$ or $F = ma$, $a = \Delta v / \Delta t$, and $p = mv$	1 point
For recognizing that the force causes a change in momentum or a change in velocity	1 point
For using reasonable values of momenta from the graph to calculate the momenta of the carts $F_5 = \Delta p / \Delta t = (1.25 \text{ kg}\cdot\text{m/s} - 0.25 \text{ kg}\cdot\text{m/s}) / 10 \text{ s} = 0.10 \text{ N}$ $F_1 = \Delta p / \Delta t = (-0.6 \text{ kg}\cdot\text{m/s} - -0.2 \text{ kg}\cdot\text{m/s}) / 10 \text{ s} = -0.04 \text{ N}$	1 point
For recognizing that the external force is the sum of the two forces on the cart $F_{ext} = F_5 + F_1 = 0.10 \text{ N} - 0.04 \text{ N} = 0.06 \text{ N}$	1 point
Calculating only the force on one of the carts earns a maximum of 1 point.	
<i>Alternate Solution:</i>	<i>Alternate Points</i>
<i>For recognizing that the momentum of the system is the sum of the momenta of the two carts</i>	<i>1 point</i>
<i>For obtaining reasonable values of momenta from the graph and using them to calculate the system momenta</i>	<i>1 point</i>
$p_{\text{system initial}} = -\frac{0.5 \text{ kg}\cdot\text{m/s}}{3} + 0.25 \text{ kg}\cdot\text{m/s} = 0.08 \text{ kg}\cdot\text{m/s}$	
$p_{\text{system final}} = -\left(\frac{6}{5}\right)(0.5 \text{ kg}\cdot\text{m/s}) + 1.25 \text{ kg}\cdot\text{m/s} = 0.65 \text{ kg}\cdot\text{m/s}$	
<i>For using the change in the system's momentum (final value minus initial value)</i>	<i>1 point</i>
$\Delta p_{\text{system}} = 0.65 \text{ kg}\cdot\text{m/s} - 0.08 \text{ kg}\cdot\text{m/s} = 0.57 \text{ kg}\cdot\text{m/s}$	
<i>For using the relationship between force and momentum to determine the external force</i>	<i>1 point</i>
$F = \Delta p / \Delta t = 0.57 \text{ kg}\cdot\text{m/s} / 10 \text{ s} = 0.057 \text{ N}$	

Question 1 (continued)

**Distribution
of points**

(c) 2 points

2 points

For a correct, justified response about the effect of changing the masses of the carts

For example:

No. The calculations in part (b) account for the effect of the external force on the motion of the entire system. The changes in individual masses do not change the total mass of the system, so the net effect on the system remains the same.

In the absence of other correct reasoning, recognizing that the mass is the same for both situations earned 1 point.

Information for Free-Response Question 2

Timing	The student should spend approximately 20–25 minutes on this question.
Essential Knowledge	<p>3.B.3 Restoring forces can result in oscillatory motion. When a linear restoring force is exerted on an object displaced from an equilibrium position, the object will undergo a special type of motion called simple harmonic motion. Examples should include gravitational force exerted by the Earth on a simple pendulum and mass-spring oscillator.</p> <p>5.B.3 A system with internal structure can have potential energy. Potential energy exists within a system if the objects within that system interact with conservative forces.</p>
Science Practice	<p>1.4 The student can use representations and models to analyze situations or solve problems qualitatively and quantitatively.</p> <p>2.2 The student can apply mathematical routines to quantities that describe natural phenomena.</p> <p>4.2 The student can design a plan for collecting data to answer a particular scientific question.</p> <p>5.1 The student can analyze data to identify patterns or relationships.</p>
Learning Objectives	<p>3.B.3.2 The student is able to design a plan and collect data in order to ascertain the characteristics of the motion of a system undergoing oscillatory motion caused by a restoring force.</p> <p>3.B.3.3 The student can analyze data to identify qualitative or quantitative relationships between given values and variables (i.e., force, displacement, acceleration, velocity, period of motion, frequency, spring constant, string length, mass) associated with objects in oscillatory motion to use that data to determine the value of an unknown.</p> <p>5.B.3.2 The student is able to make quantitative calculations of the internal potential energy of a system from a description or diagram of that system.</p> <p>5.B.3.3 The student is able to apply mathematical reasoning to create a description of the internal potential energy of a system from a description or diagram of the objects and interactions in that system.</p>

<p>Characteristics of a STRONG Response</p>	<p>Part (a) The student is able to draw a graph with the following properties:</p> <ul style="list-style-type: none"> • A reasonable sine squared shape • Maxima located at the times labeled on the axis • A difference between maximum and minimum potential energy of about 0.16 J. <p>Part (b) The student is able to draw a graph with the following properties:</p> <ul style="list-style-type: none"> • A sine or cosine curve • An appropriate phase relationship to the given graphs (i.e., the acceleration is at a positive maximum at $t = 0$ and the period is 1.0 s) • An amplitude of approximately 10 m/s^2 <p>Part (c) The student describes an experimental setup with the following characteristics:</p> <ul style="list-style-type: none"> • The setup allows useful measurements • An indication of all measurements needed with no extraneous ones • Evidence of multiple trails. <p>Part (d) The student provides an analysis of the data that includes the following:</p> <ul style="list-style-type: none"> • A check for a linear relationship between force and rubber band elongation • Indication of a correct characteristic that signifies a linear relationship • No assumption of linearity.
<p>Characteristics of a GOOD Response</p>	<p>Part (a) The student is able to draw a graph with any two of following properties:</p> <ul style="list-style-type: none"> • A reasonable sine squared shape • Maxima located at the times labeled on the axis • A difference between maximum and minimum potential energy of about 0.16 J. <p>Part (b) The student is able to draw a graph with any two of the following properties:</p> <ul style="list-style-type: none"> • A sine or cosine curve • An appropriate phase relationship to the given graphs (i.e., the acceleration is at a positive maximum at $t = 0$ and the period is 1.0 s) • An amplitude of approximately 10 m/s^2 <p>Part (c) The student describes an experimental setup with any two of the following characteristics:</p> <ul style="list-style-type: none"> • The setup allows useful measurements • An indication of all measurements needed with no extraneous ones • Evidence of multiple trails. <p>Part (d) The student provides an analysis of the data that includes any two the following:</p> <ul style="list-style-type: none"> • A check for a linear relationship between force and rubber band elongation • Indication of a correct characteristic that signifies a linear relationship • No assumption of linearity.

<p>Characteristics of a WEAK Response</p>	<p>Part (a) The student is able to draw a graph with only one or none of the following properties:</p> <ul style="list-style-type: none"> • A reasonable sine squared shape • Maxima located at the times labeled on the axis • A difference between maximum and minimum potential energy of about 0.16 J. <p>Part (b) The student is able to draw a graph with only one or none of the following properties:</p> <ul style="list-style-type: none"> • A sine or cosine curve • An appropriate phase relationship to the given graphs (i.e., the acceleration is at a positive maximum at $t = 0$ and the period is 1.0 s) • An amplitude of approximately 10 m/s^2 <p>Part (c) The student describes an experimental setup with only one or none of the following characteristics:</p> <ul style="list-style-type: none"> • The setup allows useful measurements • An indication of all measurements needed with no extraneous ones • Evidence of multiple trails. <p>Part (d) The student provides an analysis of the data that includes only one or none of the following:</p> <ul style="list-style-type: none"> • A check for a linear relationship between force and rubber band elongation • Indication of a correct characteristic that signifies a linear relationship.
--	---

Scoring Guidelines for Free-Response Question 2

Question 2

12 points total

Distribution of points

(a) 3 points

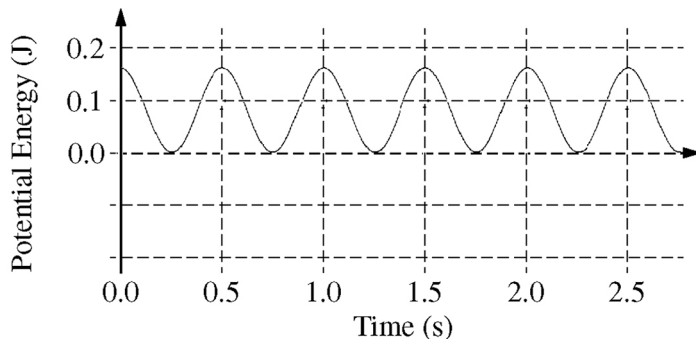

Zero potential energy can be defined at any point. For convenience define it to be at the equilibrium point of the hanging object. The graph above uses this definition.

Then $E = U + K = \frac{1}{2}mv_{\max}^2$, so

$$U = \frac{1}{2}mv_{\max}^2 - K = \frac{1}{2}mv_{\max}^2 - \frac{1}{2}m[v(t)]^2.$$

The amplitude of the velocity graph is approximately 1.6 m/s, and the period is 1 s. So $v(t) = (1.6 \text{ m/s})\sin(2\pi t/1 \text{ s})$.

$$U = \frac{1}{2}(0.125 \text{ kg})(1.6 \text{ m/s})^2(1 - \sin^2(2\pi t/1 \text{ s})) = (0.16 \text{ J})(1 - \sin^2(2\pi t/1 \text{ s}))$$

For a graph with a reasonable sine squared shape

1 point

For having the maxima of the graph at the labeled times

1 point

For having maxima and minima with a potential energy difference of about 0.16 J

1 point

(b) 3 points

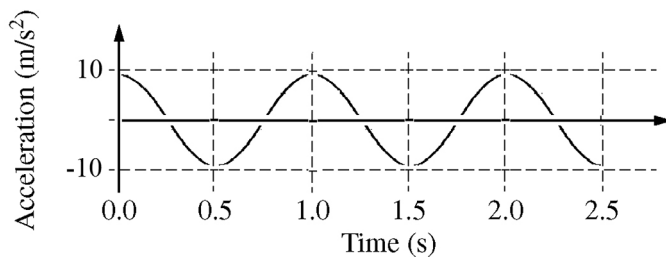

For a graph that is either a sine or cosine curve

1 point

For a graph that has the appropriate phase relationship to the given position and velocity graphs

1 point

$$a_{\max} = F_{\max}/m = kx_{\max}/m$$

The spring constant k can be determined using the period.

$$T = 2\pi\sqrt{m/k}, \text{ so } k = 4\pi^2 m/T^2 = 4\pi^2(0.125 \text{ kg})/(1 \text{ s})^2 = 0.5\pi^2 \text{ kg/s}^2$$

$$a = (0.5\pi^2 \text{ kg/s}^2)(0.25 \text{ m})/0.125 \text{ kg} = 9.87 \text{ m/s}^2$$

For an amplitude of approximately 10 m/s²

1 point

Question 2 (continued)

Distribution
of points

- (c) 3 points
- For a reasonable experimental setup that would allow useful measurements 1 point
 - For indicating all measurements needed and no extraneous ones 1 point
 - For evidence that multiple trials are performed 1 point
 - For example: Hook the rubber band over a horizontal rod, and measure its length. Hang an object of known mass from it and measure the new length. Repeat for a number of different objects.
- (d) 3 points
- For an appropriate analysis that would check for a linear relationship between force and rubber band stretch 1 point
 - For indicating an appropriate characteristic from the analysis that signifies a linear relationship 1 point
 - For indicating that a linear graph means that the rubber band exhibits $F \propto x$ like an ideal spring 1 point
 - For example: Plot the rubber band stretch as a function of the mass of the objects. A linear graph would show that the stretch and the force exerted on the rubber band (i.e. the weight of the object) are directly proportional, as they are for a spring.

Information for Free-Response Question 3

Timing	The student should spend approximately 20–25 minutes on this question.
Essential Knowledge	<p>1.B.1 Electric charge is conserved. The net charge of a system is equal to the sum of the charges of all the objects in the system.</p> <p>5.B.9 Kirchhoff’s loop rule describes conservation of energy in electrical circuits. The application of Kirchhoff’s laws to circuits is introduced in Physics 1 and further developed in Physics 2 in the context of more complex circuits, including those with capacitors.</p> <p>5.C.3 Kirchhoff’s junction rule describes the conservation of electric charge in electrical circuits. Because charge is conserved, current must be conserved at each junction in the circuit. Examples should include circuits that combine resistors in series and parallel. [Physics 1: covers circuits with resistors in series, with at most one parallel branch, one battery only.]</p>
Science Practices	<p>2.2 The student can make claims and predictions about natural phenomena based on scientific theories and models.</p> <p>6.4 The student can make claims and predictions about natural phenomena based on scientific theories and models.</p>
Learning Objectives	<p>1.B.1.1 The student is able to make claims about natural phenomena based on conservation of electric charge.</p> <p>5.B.9.3 The student is able to apply conservation of energy (Kirchhoff’s loop rule) in calculations involving the total electric potential difference for complete circuit loops with only a single battery and resistors in series and/or in, at most, one parallel branch.</p> <p>5.C.3.1 The student is able to apply conservation of electric charge (Kirchhoff’s junction rule) to the comparison of electric current in various segments of an electrical circuit with a single battery and resistors in series and in, at most, one parallel branch and predict how those values would change if configurations of the circuit are changed.</p>
Characteristics of a STRONG Response	<p>Part (a) Of the five aspects that can be identified between the two observers, the student is able to correctly identify four or five aspects of reasoning as correct or incorrect, and explain why.</p> <p>Part (b) The student is able to identify equations 1 and 3 as support for Student 1’s reasoning, and equation 4 as support for Student 2’s reasoning with correct explanations.</p> <p>Part (c) The student is able to</p> <ul style="list-style-type: none"> • Indicate a valid quantity to compare brightness • Manipulate equations to determine the quantity • Use the work to arrive at a conclusion • Explain how the calculations support the conclusion.

<p>Characteristics of a GOOD Response</p>	<p>Part (a) Of the five aspects that can be identified between the two observers, the student is able to correctly identify three or four aspects of reasoning as correct or incorrect, and explain why.</p> <p>Part (b) The student is able to identify equation 1 OR 3 as support for Student 1's reasoning, and equation 4 as support for Student 2's reasoning with correct explanations.</p> <p>OR</p> <p>The student is able to identify equation 1 and 3 as support for Student 1's reasoning, and fails to identify equation 4 as support for Student 2's reasoning with correct explanations.</p> <p>Part (c) The student is able to</p> <ul style="list-style-type: none"> • Indicate a valid quantity to compare brightness • Manipulate equations to determine the quantity • Use the work to arrive at a conclusion.
<p>Characteristics of a WEAK Response</p>	<p>Part (a) Of the five aspects that can be identified between the two observers, the student is able to correctly identify less than three aspects of reasoning as correct or incorrect, and explain why.</p> <p>Part (b) The student is able to identify equation 1 OR 3 as support for Student 1's reasoning, OR equation 4 as support for Student 2's reasoning with correct explanations.</p> <p>Part (c) The student is able to indicate a valid quantity to compare brightness and/or manipulate equations to determine the quantity.</p>

Scoring Guidelines for Free-Response Question 3

Question 3

12 points total	Distribution of points
(a) 5 points	
(i) For indicating that Student 1 is correct that bulbs <i>A</i> and <i>B</i> “get all the current coming out of the battery”, and explaining that it is because there is only one loop in the circuit	1 point
For indicating that bulbs <i>C</i> and <i>D</i> each get half the current, and explaining that it is because of the junction rule	1 point
(ii) For indicating that while bulbs <i>C</i> and <i>D</i> do get half the current in their circuit, Student 1 is incorrect in assuming that this means they must have less current than <i>A</i> and <i>B</i> , and explaining that it is because the total current is not the same in both circuits	1 point
(iii) For indicating that Student 2 is correct that the potential difference across bulbs <i>C</i> and <i>D</i> is the same and equal to the battery voltage, and explaining that for each bulb you can trace a loop that only goes through the bulb and the battery	1 point
(iv) For indicating that Student 2 is incorrect in saying that current is “used up” by bulb <i>A</i> before it reaches bulb <i>B</i> , and explaining that a current moves an equal amount of charge through all the circuit elements carrying it	1 point
(b) 3 points	
(i) Equations 1 and 3 support Student 1’s reasoning. For indicating that equation 1 shows that series bulbs <i>A</i> and <i>B</i> each carry the total current in the circuit	1 point
For indicating that equation 3 shows that parallel bulbs <i>C</i> and <i>D</i> share the total current in the circuit	1 point
(ii) Equation 4 directly supports Student 2’s reasoning. Equation 2 can also be considered as providing support for the implied contrast between circuits. For indicating that equation 4 shows that the potential difference across bulbs <i>C</i> and <i>D</i> is the same	1 point
No penalty for also indicating that equation 2 shows that the voltage is shared in the series circuit.	

Question 3 (continued)

Distribution
of points

- (c) 4 points
- For indicating a valid quantity that can be used to compare bulb brightness across circuits (power, current, or voltage) 1 point
- For correctly manipulating equations in an attempt to determine some quantity for the circuits with a valid assumption 1 point
- For stating a conclusion that follows from the work for the two points above (even if that work is incorrect) 1 point
- For explaining how the calculations support the conclusion (connecting ideas by using the chosen valid quantity to determine how it affects power which determines brightness) 1 point
- For example, calculating currents and comparing power:
- Substituting I_S into equation 2 and solving gives $I_S = \Delta V / (R_A + R_B)$
- Solving each part of equation 4 gives $I_C = \Delta V / R_C$ and $I_D = \Delta V / R_D$
- Since the resistors are identical, $I_S = I_C / 2 = I_D / 2$
- Power is given by $P = I^2 R$, and for identical resistors depends on the current. Therefore the power and thus the brightness of bulbs A and B is less.

Information for Free-Response Question 4

Timing	The student should spend approximately 10–13 minutes on this question.
Essential Knowledge	<p>6.D.1 Two or more wave pulses can interact in such a way as to produce amplitude variations in the resultant wave. When two pulses cross, they travel through each other; they do not bounce off each other. Where the pulses overlap, the resulting displacement can be determined by adding the displacements of the two pulses. This is called superposition.</p> <p>6.D.3 Standing waves are the result of the addition of incident and reflected waves that are confined to a region and have nodes and antinodes. Examples should include waves on a fixed length of string, and sound waves in both closed and open tubes.</p>
Science Practice	<p>1.1 The student can create representations and models of natural or man-made phenomena and systems in the domain.</p> <p>6.4 The student can make claims and predictions about natural phenomena based on scientific theories and models.</p>
Learning Objective	<p>6.D.1.1 The student is able to use representations of individual pulses and construct representations to model the interaction of two wave pulses to analyze the superposition of two pulses.</p> <p>6.D.3.2 The student is able to predict properties of standing waves that result from the addition of incident and reflected waves that are confined to a region and have nodes and antinodes.</p>
Characteristics of a STRONG Response	<p>Part (a) The student is able to draw a picture of a correct overlapping segment of constructive interference with an amplitude $2A$ and 2 wavelengths of amplitude A on both sides.</p> <p>Part (b) The student is able to draw a straight line on the time axis from $t = 0$ to $t = t_1$.</p> <p>Part (c) The student is able to recognize that standing waves exist at only certain frequencies and wavelengths. With the ends of the string fixed and acting as nodes, standing waves can occur with whole number multiples of antinodes. Because 2 antinodes are required for a full wavelength, the string can be whole number multiples of half the wavelength.</p>
Characteristics of a GOOD Response	<p>Part (a) The student is able to draw a representation of constructive interference in the middle, but does not show the parts of the pulses outside the area of interference.</p> <p>Part (b) The student draws a horizontal line, but not on the time axis.</p> <p>Part (c) The student is able to recognize that the string can be a multiple of half of the wavelength, but doesn't have a reasonable justification.</p>

Characteristics of a WEAK Response	<p>Part (a) The student shows complete destructive interference in the middle of the drawing.</p> <p>OR</p> <p>The student draws something completely unrelated to the problem.</p> <p>Part (b) The student draws anything other than a horizontal line.</p> <p>Part (c) The student states that the string is a multiple of the wavelength.</p>
---	--

Scoring Guidelines for Free-Response Question 4

Question 4

7 points total

Distribution
of points

(a) 3 points

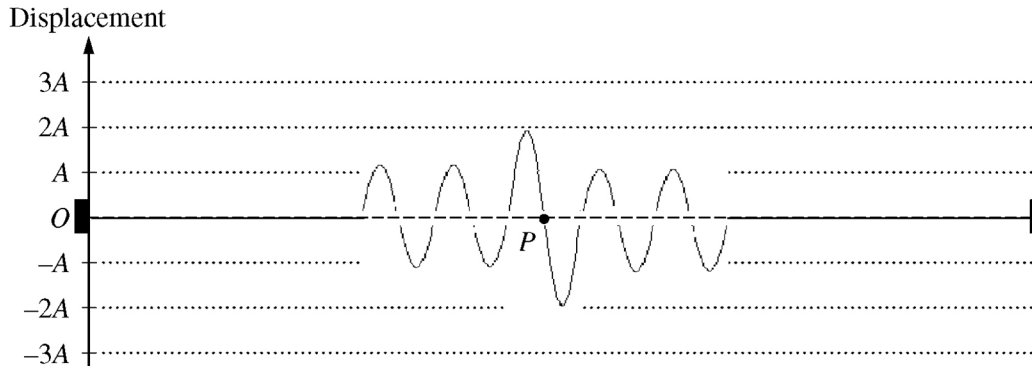

For overlap of one wavelength showing something other than amplitude A

1 point

For showing amplitude $2A$ in the overlapping segment

1 point

For showing two wavelengths of amplitude A on both sides

1 point

(b) 2 points

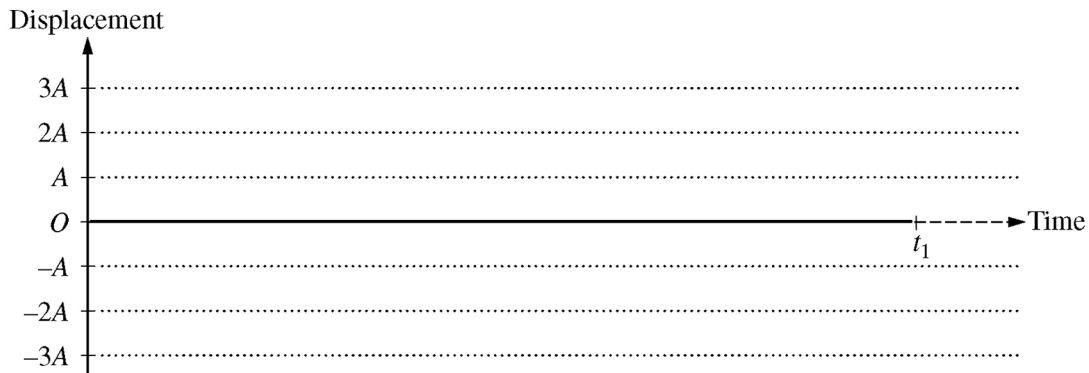

For a straight line at zero displacement

2 points

(c) 2 points

For a complete, correct response with justification

2 points

For example: The length is either a multiple of λ or $\lambda/2$. The ends are nodes, so the pattern has zero amplitude at the ends. That can only happen if the 'middle' or 'end' of a wavelength is at each end.

Information for Free-Response Question 5

Timing	The student should spend approximately 10–13 minutes on this question.
Essential Knowledge/ Big Idea	<p>3.A.3 A force exerted on an object is always due to the interaction of that object with another object.</p> <p>3.A.4 If one object exerts a force on a second object, the second object always exerts a force of equal magnitude on the first object in the opposite direction.</p> <p>3.E.1 The change in the kinetic energy of an object depends on the force exerted on the object and on the displacement of the object during the time interval that the force is exerted.</p> <p>4.C.1 The energy of a system includes its kinetic energy, potential energy, and microscopic internal energy. Examples should include gravitational potential energy, elastic potential energy, and kinetic energy.</p> <p>5.B.3 A system with internal structure can have potential energy. Potential energy exists within a system if the objects within that system interact with conservative forces.</p> <p>5.D.1 In a collision between objects, linear momentum is conserved. In an elastic collision, kinetic energy is the same before and after.</p> <p>5.D.3 The velocity of the center of mass of the system cannot be changed by an interaction within the system. [Physics 1: includes no calculations of centers of mass; the equation is not provided until Physics 2. However, without doing calculations, Physics 1 students are expected to be able to locate the center of mass of highly symmetric mass distributions, such as a uniform rod or cube of uniform density, or two spheres of equal mass.]</p>
Science Practice	<p>6.4 The student can make claims and predictions about natural phenomena based on scientific theories and models.</p> <p>7.2 The student can connect concepts in and across domain(s) to generalize or extrapolate in and/or across enduring understandings and/or big ideas.</p>

<p>Learning Objective</p>	<p>3.A.3.1 The student is able to analyze a scenario and make claims (develop arguments, justify assertions) about the forces exerted on an object by other objects for different types of forces or components of forces.</p> <p>3.A.4.1 The student is able to construct explanations of physical situations involving the interaction of bodies using Newton's third law and the representation of action-reaction pairs of forces.</p> <p>3.E.1.1 The student is able to make predictions about the changes in kinetic energy of an object based on considerations of the direction of the net force on the object as the object moves.</p> <p>4.C.1.2 The student is able to predict changes in the total energy of a system due to changes in position and speed of objects or frictional interactions within the system.</p> <p>5.B.3.1 The student is able to describe and make qualitative and/or quantitative predictions about everyday examples of systems with internal potential energy.</p> <p>5.D.1.1 The student is able to make qualitative predictions about natural phenomena based on conservation of linear momentum and restoration of kinetic energy in elastic collisions.</p> <p>5.D.3.1 The student is able to predict the velocity of the center of mass of a system when there is no interaction outside of the system but there is an interaction within the system (i.e., the student simply recognizes that interactions within a system do not affect the center of mass motion of the system and is able to determine that there is no external force).</p>
<p>Characteristics of a STRONG Response</p>	<p>The student explains in a clear and logical manner the correct differences in energy conversions between the two trials. Specifically, the student indicates that in the first trial the block's potential energy at the top of the plane is converted to kinetic energy that is shared between the block and plane at the bottom, while in the second trial the potential energy is completely converted to kinetic energy of the block. In addition, the student correctly explains the motion of the plane in each trial. Finally, the student uses the explanations to conclude that the block moves faster in Trial 2.</p>
<p>Characteristics of a GOOD Response</p>	<p>The student makes all of the connections but leaves out the description of the plane's motion for each trial.</p>
<p>Characteristics of a WEAK Response</p>	<p>The student makes no connection between the information given and the conversion of potential energy to kinetic energy.</p>

Scoring Guidelines for Question 5

Question 5

7 points total

Distribution
of points

For any mention of energy conversion	1 point
For indicating that the same amount of potential energy is converted to kinetic energy in each trial	1 point
For indicating that the kinetic energy is shared between the block and plane in trial 1	1 point
For indicating that the block has all the kinetic energy in trial 2	1 point
For a description of the motion of the plane in each trial	1 point
For using momentum or forces to explain the motion in each trial	1 point
For a coherent argument that leads to a correct conclusion	1 point
For example: The speed of the block is greater in trial 2. Since gravity is the only force doing work in both trials, energy is conserved. The potential energy of the block at the top of the plane is converted into kinetic energy. In trial 1 the plane is free to move, so if the block ends up going to the right, the plane has to move to the left to conserve momentum. <i>[Alternate: In trial 1 the plane is free to move, so if the plane pushes the block to the right, the block pushes the plane to the left.]</i> Since the plane moves, the original potential energy of the block must be divided between the plane and the block. In trial 2 the plane doesn't move, so the block gets all of the available energy. More kinetic energy means a greater speed.	

Contact Us

New York Office

45 Columbus Avenue
New York, NY 10023-6992
212-713-8000
212-713-8277/55 (Fax)

AP Services for Educators

P.O. Box 6671
Princeton, NJ 08541-6671
877-274-6474 (toll free in the United States and Canada)
212-632-1781
610-290-8979 (fax)
Email: apexams@info.collegeboard.org

Call Center Hours

M–F, 8 a.m. to 5 p.m. ET
April 21 to May 23, 2014, M–F, 7 a.m. to 8 p.m. ET

AP Canada Office

2950 Douglas Street, Suite 550
Victoria, BC, Canada V8T 4N4
250-472-8561
800-667-4548 (toll free in Canada only)
Email: gewonus@ap.ca

International Services

Serving all countries outside the U.S. and Canada
45 Columbus Avenue
New York, NY 10023-6992
212-373-8738
Email: international@collegeboard.org

